

IMPORTANT SAFETY NOTICES

PREVENTION OF PHYSICAL INJURY

1. Before disassembling or assembling parts of the printer and peripherals, make sure that the power cord is unplugged.
2. The wall outlet should be near the copier and easily accessible.
3. If any adjustment or operation check has to be made with exterior covers off or open while the main switch is turned on, keep hands away from electrified or mechanically driven components.

HEALTH SAFETY CONDITIONS

1. If you get ink in your eyes by accident, try to remove it with eye drops or flush with water as first aid. If unsuccessful, get medical attention.
2. If you ingest ink by accident, induce vomiting by sticking a finger down your throat or by giving soapy or strong salty water to drink.

OBSERVANCE OF ELECTRICAL SAFETY STANDARDS

1. The printer and its peripherals must be installed and maintained by a customer service representative who has completed the training course on those models.

CAUTION

The RAM board has a lithium battery which can explode if handled incorrectly. Replace only with the same type of RAM board. Do not recharge or burn this battery. Used RAM boards must be handled in accordance with local regulations.

ATTENTION

La carte RAM comporte une pile au lithium qui présente un risque d'explosion en cas de mauvaise manipulation. Remplacer la pile uniquement par une carte RAM identique. Ne pas recharger ni brûler cette pile. Les cartes RAM usagées doivent être éliminées conformément aux réglementations locales.

SAFETY AND ECOLOGICAL NOTES FOR DISPOSAL

1. Dispose of replaced parts in accordance with local regulations.
2. Used ink and masters should be disposed of in an environmentally safe manner and in accordance with local regulations.
3. When keeping used lithium batteries (from the main control boards) in order to dispose of them later, do not store more than 100 batteries (from the main control boards) per sealed box. Storing larger numbers or not sealing them apart may lead to chemical reactions and heat build-up.

TABLE OF CONTENTS

1. OVERALL MACHINE INFORMATION	1-1
1.1 SPECIFICATIONS	1-1
1.2 MAJOR DIFFERENCES BETWEEN THE C223 AND THE C228.....	1-4
2. DETAILED SECTION DESCRIPTIONS.....	2-1
2.1 MASTER EJECT	2-1
2.2 MASTER FEED.....	2-2
2.2.1 MASTER FEED MECHANISMS.....	2-2
2.2.2 THERMAL HEAD PRESSURE RELEASE MECHANISM	2-4
2.3 PAPER FEED	2-5
2.3.1 PAPER FEED ROLLER.....	2-6
2.3.2 PAPER SEPARATION PLATE	2-7
2.4 PRINTING.....	2-8
2.4.1 OVERVIEW.....	2-8
Printing Pressure Cam.....	2-8
Paper Detection and Printing	2-8
Quality Start.....	2-9
2.4.2 PAPER DETECTION AND PRINTING PRESSURE ON/OFF MECHANISM	2-10
2.5 IMAGE PROCESSING.....	2-11
2.5.1 OVERVIEW.....	2-11
2.5.2 MASTER MAKING	2-12
2.5.3 THERMAL HEAD PROTECTION	2-12
2.6 PAPER MISFEED DETECTION.....	2-13
3. INSTALLATION.....	3-1
3.1 INSTALLATION REQUIREMENTS	3-1
3.1.1 OPTIMUM ENVIRONMENTAL CONDITIONS.....	3-1
3.1.2 ENVIRONMENTS TO AVOID.....	3-2
3.1.3 POWER CONNECTION.....	3-3
3.1.4 ACCESS TO THE MACHINE	3-4
3.2 ACCESSORY CHECK	3-5
3.3 INSTALLATION PROCEDURE	3-6
4. SERVICE TABLES.....	4-1
4.1 SERVICE REMARKS.....	4-1
4.2 SERVICE TABLES.....	4-2
4.2.1 MAINTENANCE TABLES.....	4-2
Lubrication Points	4-2
User's Maintenance	4-5
Periodic Inspection (every 6 months).....	4-5
Periodic Inspection (every 12 months).....	4-6
4.2.2 SERVICE CALL CODES	4-7

4.2.3	DIP SWITCHES, LEDS, VRS, TPS (ON THE MAIN CONTROL PCB)	4-10
	DIP Switches	4-10
	Photodiodes.....	4-10
	VRs.....	4-11
	TPs.....	4-11
4.2.4	EXPECTED LIFE OF PARTS	4-11
4.2.5	SPECIAL TOOLS	4-12
4.3	SERVICE PROGRAM MODE.....	4-13
4.3.1	SERVICE PROGRAM MODE OPERATION	4-13
	Service Program Mode Access Procedure (for engineers).....	4-13
	Service Program Mode Access Procedure (for users)	4-14
	Change Adjustment Values or Modes.....	4-14
4.3.2	SERVICE PROGRAM TABLE	4-15
4.3.3	THERMAL HEAD TEST	4-32
4.3.4	COMMAND SHEET CHECK	4-33
4.3.5	INPUT/OUTPUT CHECK MODE	4-34
	Input Check Mode Access Procedure	4-34
	Output Check Mode Access Procedure	4-34
	Input Check Table.....	4-35
4.3.6	USER CODE MODE.....	4-42
	User Codes.....	4-42
	How To Use a User Code	4-42
5.	REPLACEMENT AND ADJUSTMENT	5-1
5.1	MASTER FEED.....	5-1
5.1.1	THERMAL HEAD VOLTAGE ADJUSTMENT	5-1
5.2	PAPER FEED	5-3
5.2.1	SECOND FEED ROLLER START TIMING.....	5-3
5.2.2	PAPER FEED ROLLER REMOVAL	5-5
5.3	DELIVERY	5-6
5.3.1	EXIT PAWL TIMING ADJUSTMENT	5-6
6.	POINT TO POINT DIAGRAM (C228).....	6-1

SECTION 1
OVERALL MACHINE
INFORMATION

1. OVERALL MACHINE INFORMATION

1.1 SPECIFICATIONS

Configuration:	Table-top
Master Processing:	Digital
Printing Process:	Fully automatic one-drum stencil system
Original Type:	Sheet/Book
Original Size:	Maximum 307 mm x 432 mm (12.0" x 17.0")
Reduction Ratios:	Inch version: 93%, 77%, 74%, 65% Metric version: 93%, 87%, 82%, 71%
Enlargement Ratios:	Inch version: 155%, 129%, 121% Metric Version: 141%, 122%, 115%
Zoom:	From 50% to 200% in 1% steps
Directional Magnification:	Vertical: From 50% to 200% in 1% steps Horizontal: From 50% to 200% in 1% steps
Image Mode:	Letter, Photo, Letter/Photo
Color Printing:	Drum unit replacement system (Red, Blue, Green, Brown, Yellow, Purple, Navy, and Maroon)
Master Feed/Eject:	Roll master, automatic feed/eject
Leading Edge Margin:	5 mm (0.2")
Trailing Edge Margin:	3 mm (0.12")
Print Paper Size:	Maximum 297 mm x 432 mm (11.6" x 17.0") Minimum 90 mm x 148 mm (3.6" x 5.8")
Printing Area:	A3 drum (original drum) More than 290 mm x 412 mm Optional A3 drum More than 290 mm x 407 mm Optional A4 drum More than 290 mm x 204 mm
Print Paper Weight:	47.1 g/m ² to 209.3 g/m ² (12.5 lb to 55.6 lb)

Printing Speed: 60, 75, 90, 105, 120 sheets/minute
 First Copy Time (Master Process Time): Less than 46.0 seconds (A3)
 Less than 37.0 seconds (A4)
 Second Copy time (First Print Time): Less than 48.0 seconds (A3)
 Less than 39.5 seconds (A4)
 Paper Feed Table Capacity: 1,000 sheets (80 g/m², 20 lb)
 Paper Delivery Table Capacity: 1,000 sheets (80 g/m², 20 lb)
 Power Source: 120 V, 50/60 Hz: 3.6 A (for N. America)
 220/240 V, 50/60 Hz: 2.0 A (for Europe, Asia)
 Power Consumption: 120 V, 50/60 Hz: 360 W (for N. America)
 220/240 V, 50/60 Hz: 350 W (for Europe, Asia)
 Weight: 120 V version: 127 kg
 220/240 V version: 127 kg
 Cabinet: 23.5 kg

Dimensions (W x D x H):

	Width	Depth	Height
Stored	719 mm, 28.4"	698 mm, 27.5"	644 mm, 25.4"
Stored with document feeder	719 mm, 28.4"	698 mm, 27.5"	666 mm, 26.3"
Set up	719 mm, 28.4"	698 mm, 27.5"	644 mm, 25.4"
Set up with cabinet	719 mm, 28.4"	698 mm, 27.5"	1,070 mm, 42.2"
Set up with document feeder	1,331 mm, 52.5"	698 mm, 27.5"	666 mm, 26.3"
Set up with cabinet and document feeder	1,331 mm, 52.5"	698 mm, 27.5"	1,092 mm, 43.0"

Original Scanning Time: 3.07 ms/line
 Master Making Density: 600 dpi (CCD: 400 dpi)
 Master Eject Box Capacity: More than 70 masters under low temperature
 More than 100 masters at 23 °C, 73°F and over
 Paper Separation: Friction roller/center separation system
 Feed Table Side Plate Movement: 88 mm to 336 mm (3.46" to 13.2")
 Side Registration: ± 10 mm
 Vertical Registration: More than +10 mm, -20 mm

Ink Supply:	Automatic ink supply system
Paper Delivery:	Air knife/vacuum delivery
Print Counter:	7 digits
Supplies:	Master Thermal master 320 mm width 370 masters/roll (with A4 drum) 250 masters/roll (with A3 drum) (VT-6 master) Max. run length 2000 prints
Ink	1000 cc ink pack (black) 600 cc ink pack (Red, Blue, Green, Brown, Yellow, Purple, Navy, Maroon)

1.2 MAJOR DIFFERENCES BETWEEN THE C223 AND THE C228

No.	Item	Details
1	Thermal Head	A new 600 dpi thermal head is used.
2	Thermal Head Pressure Release Mechanism	The thermal head is pressed against the platen roller only during the master making process. A unique dc motor is used for this mechanism. For details, refer to 'Master Feed' in the Detailed Section Descriptions section.
3	Improvements for Better Master Feeding in the Master Feed Unit	The new master is thinner and has a smoother surface. Some improvements have been made to improve master feed. For details, refer to 'Master Feed' in the Detailed Section Descriptions section.
4	Paper Feed Roller	The core of the paper feed roller has been changed to improve paper feed. For details, refer to 'Paper Feed' in the Detailed Section Descriptions section.
5	Paper Separation Plate	The shape of the separation plate has been changed for better paper feeding. For details, refer to 'Paper Feed' in the Detailed Section Descriptions section.
6	Paper Feed Cam and Printing Pressure Cam	For better printing quality, the shape of the printing pressure cam (the cam profile) has been changed. Also, the shapes of the two paper feed rollers have been changed in order to make the paper registration more accurate. For details, refer to 'Paper Feed' and 'Printing' in the Detailed Section Descriptions section.
7	Paper Detection System for Starting Applying the Printing Pressure	For better printing, the printing pressure application timing has been changed. Because of the strictly controlled timing, a photocoupler (the paper registration sensor) is used to detect when to start applying the printing pressure. (The paper detection feeler used in the C223 has been removed.) For details, refer to 'Printing' in the Detailed Section Descriptions section.
8	Master Eject Roller	Grooves have been made in the lower master feed rollers to improve master feed. For details, refer to 'Master Eject' in the Detailed Section Descriptions section.

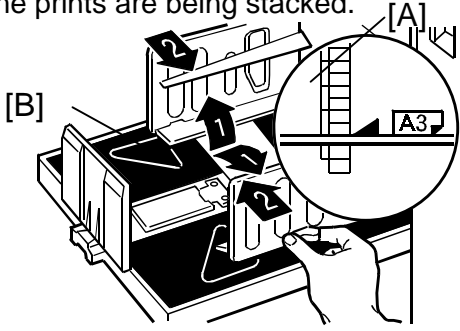
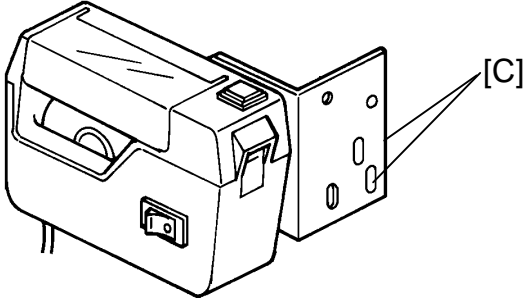
No.	Item	Details
9	Paper Delivery Table	<p>The C228 uses a new paper delivery table. (This table is also used for the recent C223 because of a modification.) This new table has small guide plates [A] on the front and rear side fences. The guide plates stack the prints more evenly. The small guide plates [B], on the bottom of each side fence, keep the prints aligned in the center of the table while the prints are being stacked.</p>  <p style="text-align: right;">C228V500.WMF</p> <p>Due to the new paper delivery table design, the set position of the optional tape marker is different from that for the C223. Use the screw holes [C] shown below.</p>  <p style="text-align: right;">C532I504.PCX</p>
10	Thermal Head Drive	<p>The voltage to the thermal heating elements in the thermal head is different from that of the C223. The DC/DC Converter Board which is newly added supplies the voltage while using the same power supply board as the C223.</p> <p>Also, the thermal head drive board used in the C223 has been removed. The function has been built into the image processing board.</p>
11	Image Shifting Mode	<p>The shift range in the backward direction in image shifting mode has been changed from 15 mm to 10 mm. This is due to the changed printing pressure application timing. (In the forward direction, it is 20 mm as before.)</p>
12	Make-up Function	<p>The memory chips for the Make-up function, which was an option for the C223, are built into the image processing board.</p>

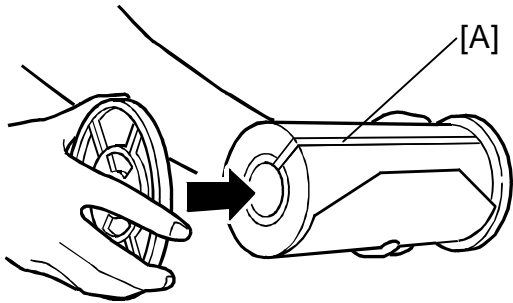
No.	Item	Details
13	New Replacement and Adjustment Procedures	<ul style="list-style-type: none"> • The thermal head voltage adjustment procedure has been changed. • The adjustment standard for the second feed roller start timing has been changed from 177° to 144°. • A remark has been added to the paper feed roller removal procedure. • The adjustment standard for the exit pawl timing has been changed from $230 \pm 2^\circ$ to $228 \pm 2^\circ$. <p>For details, refer to the Replacement and Adjustment section.</p>
14	New Master	<p>A new more heat-sensitive master is used to improve the printing quality.</p> <p>Due to the new master material, the capacity of the master eject box has been increased.</p> <p>Because the new master surface is slippery, the new master roll is tightened with tape [A] as shown below to prevent the roll from becoming loose. The master roll installation method has been changed. (For details, refer to 'Installation Procedure' in the Installation section.)</p>  <p style="text-align: right;">C228V502.WMF</p>

No.	Item	Details
15	New SP Modes	<p>The default setting for the thermal head energy for the economy mode (SP35-2) has been changed from -35% to -30%. (In other words, the energy used in economy mode has been increased.)</p> <p>The following SP modes are new for the C228: SP51: Clear Multi Copy SP52: Compress W Start Key SP78-1: Letter/Pht Mode [CS] SP78-2: Clear/Original</p> <p>Note: SP51 and SP78 are accessible to users. SP78 also can be registered in CS mode.</p> <p>- Functions -</p> <p>SP51: Resets the Combine 2 Originals or Combined Print function (if it has been set) after the master making process. There are two options: 0: No, 1: Yes. "0" is the default.</p> <p>SP52: The masters in the master eject box can be compressed every time the Master Making key is pressed. There are two options: 0: No, 1: Yes. "0" is the default.</p> <p>Note: If this mode is enabled, it reduces the possibility of the master eject belts slipping off, which tends to occur when the master box is full.</p> <p>SP78-1: Select whether the reproduction of letter mode areas is emphasized when Letter/Photo mode is used. There are two options: 0: Standard, 1: Emphasized. "0" is the default.</p> <p>SP78-2: Select whether the image mode (letter, photo, or letter/photo) is to be returned to the default setting when master making is finished. There are two options: 0: No, 1: Yes. "0" is the default.</p>
16	New Input/Output Check Mode	<p>The following are the new items for the Input/Output Check Mode:</p> <p>Input: 51 SN: Paper Registration (Paper Registration Sensor)</p> <p>Input: 52 SN: T. Head Position (Thermal Head Pressure Release Sensor)</p> <p>Output: 42 MOTOR: T. Head Up/Down (Turns on the thermal head pressure release motor.)</p>

SECTION 2
DETAILED SECTION
DESCRIPTIONS

2. DETAILED SECTION DESCRIPTIONS

2.1 MASTER EJECT

Grooves have been added on the lower master eject rollers for better master feeding.

⚠ CAUTION

The lower master eject roller must be installed the correct way around. The groove [A] on the shaft (see the illustration) must be on the operation side.

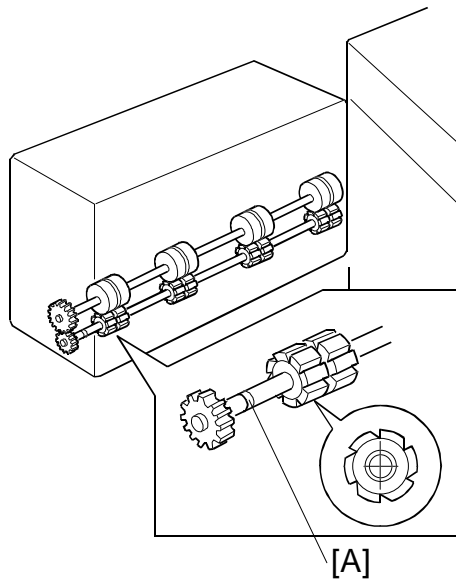

C228D501.WMF

2.2 MASTER FEED

2.2.1 MASTER FEED MECHANISMS

A 600 dpi thermal head and a new more heat-sensitive master is used to improve the printing quality. The new master is thinner and has a smoother surface. The following improvements are implemented to improve master feed.

1. Three master buffer fan motors [A] are used instead of the one fan motor used in the C223. This generates stronger suction to guide the master into the master box [B].

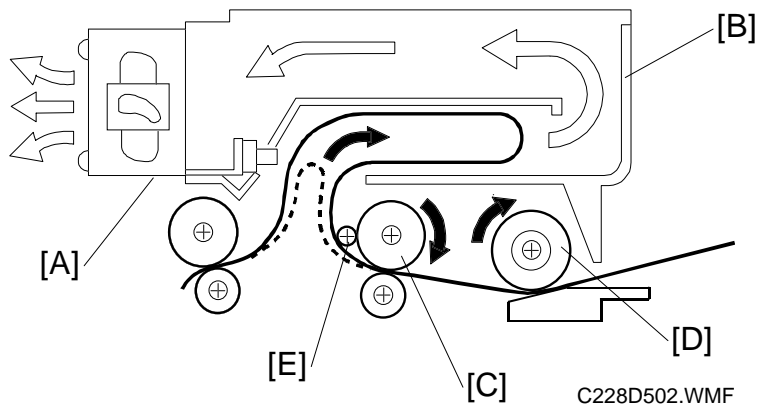

2. To ensure correct master feed, the material of the upper master feed roller [C] has been changed to an anti-static rubber. (A sponge-like material was used for the C223.)

The new master feed roller [C] rotates slightly faster than the platen roller [D]. This stretches the master on the thermal head (under the platen roller) and makes sure that the master is made accurately. A torque limiter built into the upper master feed roller gear can release the master feed force to prevent the master from being damaged in this area.

Also, the counter roller [E] has been added to prevent the master from wrapping around the upper master feed roller.

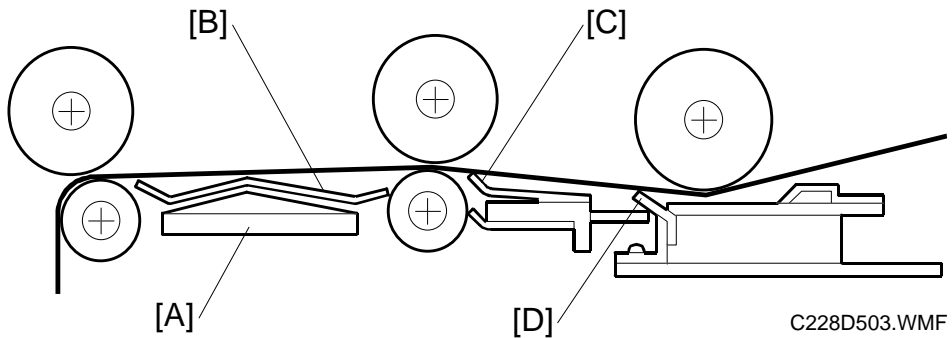

3. A metal master guide plate was used between the master feed roller and reverse roller for the C223. This was good for grounding static electricity. However, when static electricity is grounded, the master tends to stick to the guide plate. As a thinner master is used for the C228, the guide plate [A] is made of a plastic material. This prevents the master from being stuck on the guide plate surface even if static electricity is generated. Also, ribs have been added to the new guide plate to feed the master more smoothly.
4. Four strips of mylar [B] have been added to the surface of the master guide plates. This can prevent the master from catching on the rollers under the master feed and reverse rollers. Other strips of mylar are used in front of the master feed roller [C] and after the platen roller [D].

NOTE: These mylar strips must be carefully repositioned when the rollers are reinstalled.

2.2.2 THERMAL HEAD PRESSURE RELEASE MECHANISM

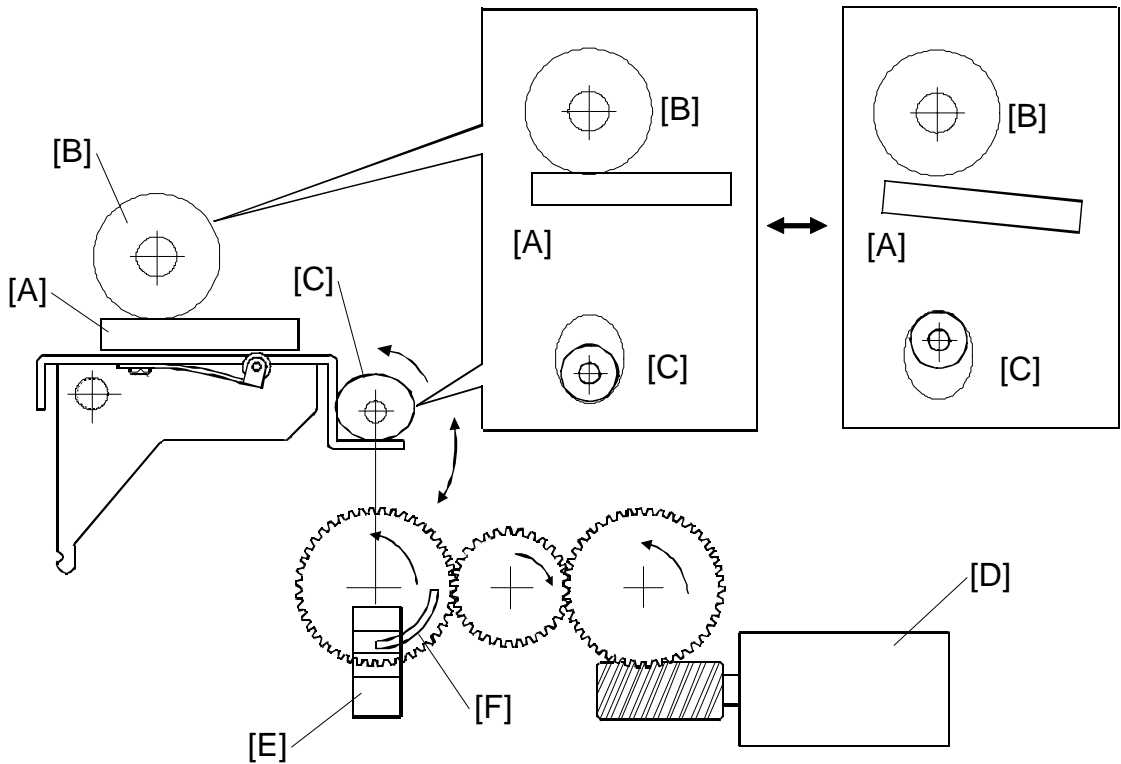

C228D504.WMF

The thermal head [A] is pressed against the platen roller [B] only during the master making process. The thermal head position is moved up and down by changing the position of the cam [C].

The cam position is changed by the thermal head pressure release motor [D] via gears. The thermal head pressure release sensor [E] monitors the cam position. The sensor, which is a photointerrupter, is interrupted by the shutter mounted on the gear [F] as the pressure release motor turns to maintain the cam position.

2.3 PAPER FEED

To improve paper feed, especially for thin paper, the paper feed roller and the separation plate have been changed.

In addition, the shapes of the two paper feed cams (the cam profiles) have been changed in order to make the paper registration more accurate.

With the new cams, the leading edge of the paper reaches the second feed roller faster than before. Then, the second feed roller can start feeding the paper earlier.

Thanks to this, the second feed roller can start feeding the paper at a lower transportation speed. (The time that the paper reaches the press roller position is still the same, but the acceleration from the second feed roller has become more moderate.) As a result, the paper registration has become more accurate.

Since the timing for the second feed roller to start feeding the paper was advanced, the paper detection feeler used in the C223 could not be used. A photocoupler is used instead. For more details about this, refer to the Printing section.

- NOTE:** 1) Due to the new cams, the adjustment values for second feed roller operation are changed. For details, refer to 'Feed Length of the Second Feed Roller Adjustment' and 'Second Feed Roller Start Timing Adjustment' in the 'Replacement and Adjustment' section. (The 'Feed Length of the Paper Feed Roller Adjustment' procedure is still the same.)
- 2) The new paper feed cams cannot be used on the older models since those models use the paper detection feeler.

2.3.1 PAPER FEED ROLLER

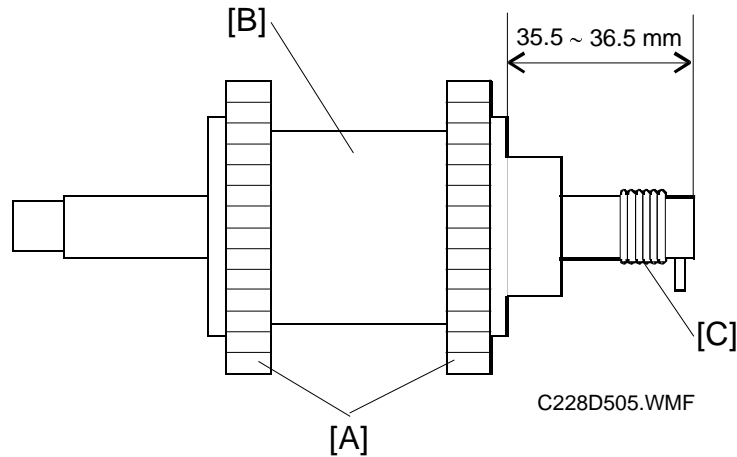

In this model, the two rubber rollers [A] on the core roller are separated. This helps to prevent creasing of paper that can be caused by the narrower roller assembly of the C223. (This was likely with very thin paper.)

The material of the core roller [B] was changed from plastic to metal for better stiffness. As a result, to balance the weight of the whole paper feed roller unit, the number of balancing weight plates on the feed roller bracket was reduced from three to two.

Since the weight of the paper feed roller itself has increased, the roller tends to overrun (it keeps on feeding paper) after the roller driving force stops. To prevent this, a spring [C] which works as a brake has been added at the end of the shaft.

NOTE: When servicing, make sure that the core roller is between 35.5 mm and 36.5 mm from the end of the shaft.

2.3.2 PAPER SEPARATION PLATE

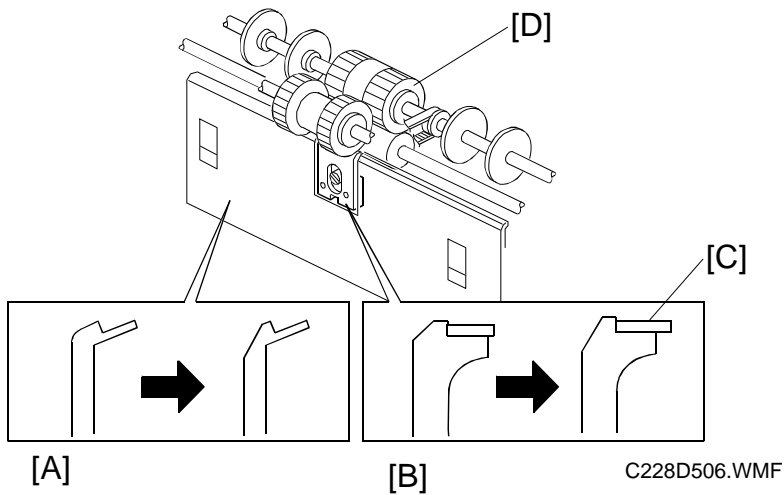

If the leading edge of paper stacked on the paper table curls downwards, it tends to be caught by the separation plate and this causes a jam. The shape of the separation plate [A] has been changed (see the diagram) to improve paper feed in such a case.

For the same purpose, the shape of the upper edge of the entrance plate [B] (which holds the separation plate) has been changed as shown.

The rubber part of the separation plate [C] has been lengthened to improve paper feed, especially for thick paper. The lengthened rubber can guide the paper leading edge to the upper separation roller [D] surface more precisely. Because of this, the paper edge hits the upper separation roller more gently. This prevents the paper leading edge from being damaged at the area where the separation plate (the rubber part) contacts the upper separation roller surface. (This was likely with thick paper.)

2.4 PRINTING

2.4.1 OVERVIEW

Printing Pressure Cam

For better printing quality, the shape of the printing pressure cam (the cam profile) has been changed.

The new cam applies printing pressure to the drum faster than before. The press roller is pressed against the ink roller (the master and the drum screens are in between) before the leading edge of the paper reaches this section.

In the C223, the press roller is pressed against the ink roller just when the paper leading edge reaches this point. In this case, the paper leading edge is strongly pressed against the master surface on the drum. Since the new master is thinner and delicate, the paper leading edge tends to damage the master surface if the same printing pressure cam is used, especially during a long printing run. (If the master surface is damaged, ink will leak and transfer onto the paper.) The new printing pressure cam can avoid this situation.

- NOTE:** 1) Because of the new printing pressure cam, the adjustment values (angles) for printing pressure application timing and exit pawl operation timing are changed. Refer to 'Pressure Timing Adjustment' and 'Exit Pawl Timing Adjustment' in the 'Replacement and Adjustment' section.
- 2) The new printing pressure cam cannot be used in the older models. Because of the new cam profile, the shift range in the backward direction in image shifting mode has been changed from 15 mm to 10 mm. (In the forward direction, it is 20 mm as before.)

Paper Detection and Printing

In the C223, the paper detection feeler was used in order to prevent the press roller from contacting the drum (without paper) and getting ink on it when a paper misfeed occurred before the paper reached the press roller.

The paper detection feeler could be pressed downwards by paper since a gap between the paper detection arm and the pressure on/off lever was created when the widest part of the pressure cam reached the bearing on the pressure on/off lever. With the earlier second feed roller start timing, this gap cannot be created. Therefore, the same mechanism is not used. (The timing was changed to make paper registration more accurate; see the Paper Feed section for details.)

NOTE: For the details of the paper detection feeler operation, refer to the C223 Service Manual. (Section 5.2, 'Paper Detection And Printing Pressure On/Off Mechanism' in the 'Detailed Section Descriptions' section.)

Instead of the paper detection feeler, the registration sensor (a photocoupler) is used. When the sensor detects the paper, the printing pressure solenoid energizes to start applying the printing pressure. (In the C223, the printing pressure solenoid was energized as soon as paper feed started.) The sensor is also used as a paper jam detector.

For more details about this mechanism, refer to the following 'Paper Detection and Printing Pressure On/Off Mechanism' section.

Quality Start

The detection arm release solenoid which was used in the C223 has been removed. Since the paper detection feeler has been removed, the detection arm release solenoid is not necessary to start the drum stroke operation in the quality start mode.

When the drum stroke operation starts, the printing pressure solenoid turns on. This disengages the pressure on/off lever and starts applying the printing pressure.

NOTE: For the details of the quality start mode operation, refer to the C223 Service Manual. (Section 5.4 'Quality Start Operation' in the 'Detailed Section Descriptions' section.)

2.4.2 PAPER DETECTION AND PRINTING PRESSURE ON/OFF MECHANISM

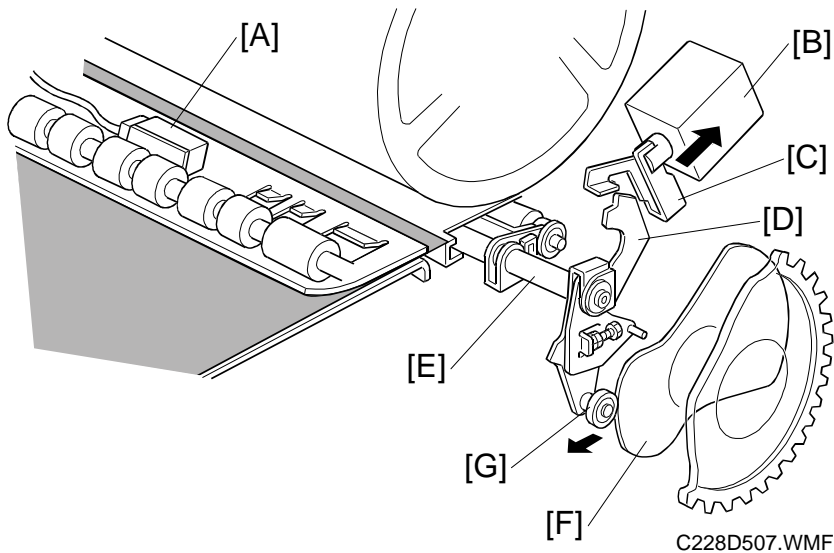

When the paper is detected by the paper registration sensor [A], the printing pressure solenoid [B] is energized. The stopper arm [C] then disengages the pressure on/off lever [D]. The pressure on/off lever, which is connected to the end of the press roller arm [E], starts moving when the printing pressure cam [F] starts moving; the cam moves bearing [G], which is on the lever. The press roller is pressed against the ink roller.

The printing pressure solenoid is de-energized when the printing pressure sensor is activated; this is soon after it is energized. The stopper arm [C] returns and is pressed against the pressure on/off lever, due to tension from a spring. (The stopper arm just rides on the edge of the pressure on/off lever at this time.) To finish applying the printing pressure, the bearing [G] on the pressure on/off lever is pushed by the printing pressure cam and the lever turns clockwise, until it is engaged by the stopper arm.

If the next sheet of paper is detected by the registration sensor within a certain period, the printing pressure solenoid is again energized to disengage the pressure on/off lever. The printing pressure for the next sheet of paper starts being applied.

If the registration sensor is not activated, the machine detects a paper misfeed condition (Location B Misfeed). In this case, the printing pressure solenoid stays de-energized and the printing pressure is not applied. This can prevent the press roller contacting the drum (without paper) and getting ink on it because of the paper misfeed.

NOTE: In the C223, Location B Misfeed was detected when the printing pressure sensor was not activated within a certain period.

2.5 IMAGE PROCESSING

2.5.1 OVERVIEW

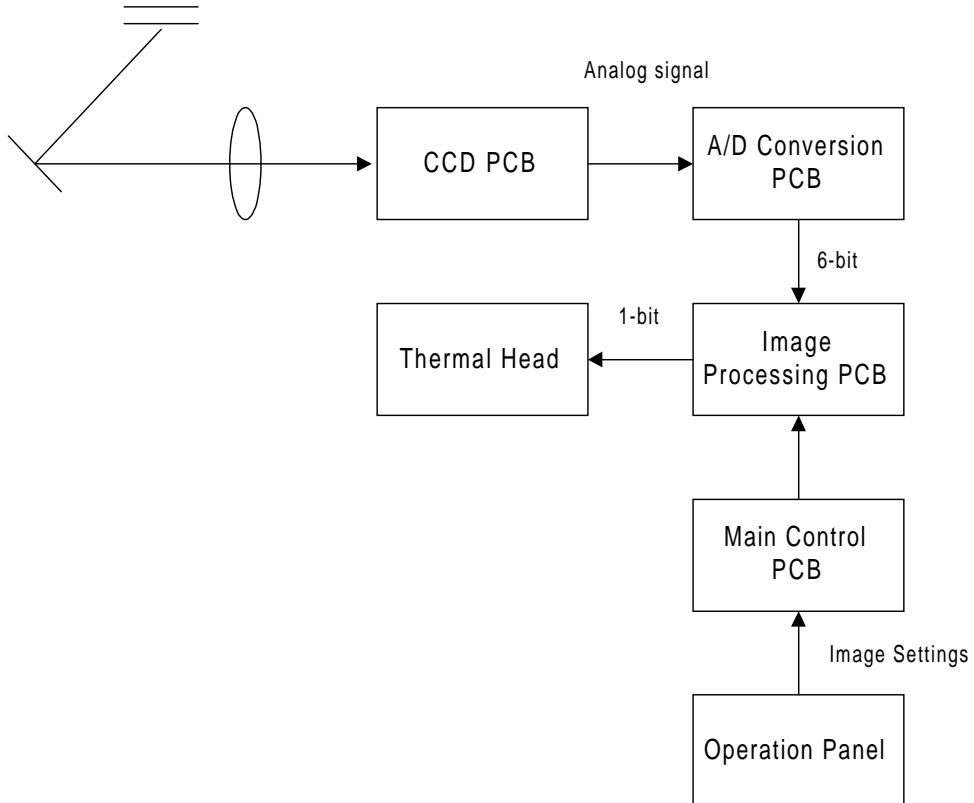

C228D508.WMF

The light reflected from the original goes to the CCD, which converts the light signal into an analog electrical signal. The analog signal is sent to the A/D conversion PCB, where it is changed to 6-bit digital data. The 6-bit data is changed to 1-bit data in the image processing PCB and it goes to the thermal head. The thermal head drive circuit is built into the image processing PCB.

The 6-bit to 1-bit conversion procedure depends on the image settings on the operation panel.

2.5.2 MASTER MAKING

The operation of the thermal head is just like that of the C223, except that the thermal head drive circuit has been built into the image processing board.

The new 600 dpi thermal head is used with the new more heat-sensitive master. The specifications of the thermal head are as follows:

- Density of Thermal Heating Elements: 600 dpi
- Number of Thermal Heating Elements: 7168 dots
- Maximum Master Making Width: 303.45 mm

2.5.3 THERMAL HEAD PROTECTION

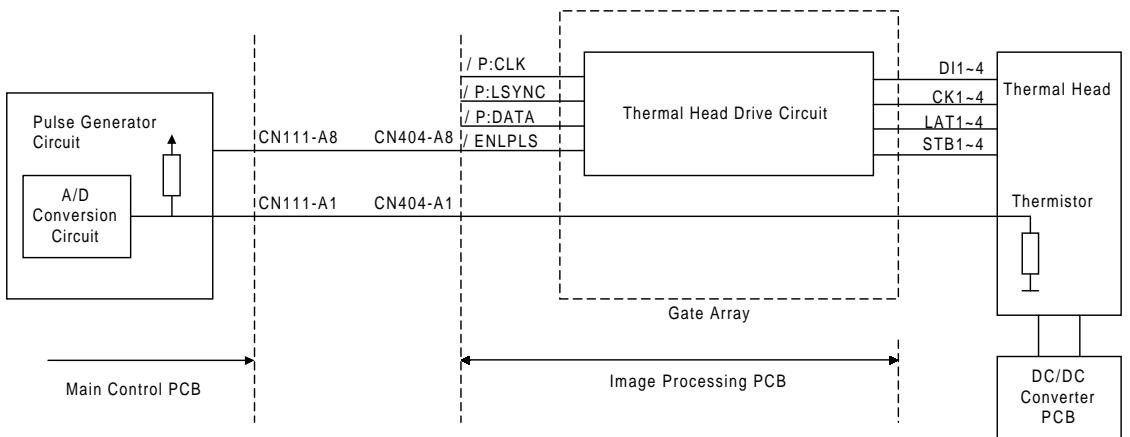

C228D509.WMF

The thermistor on the thermal heat prevents it from overheating when continuously processing a solid image.

The CPU checks for abnormal conditions when the Master Making key is pressed, and indicates an SC code on the operation panel under the following conditions:

SC Code	Conditions
E-04	The thermistor on the thermal head detected a temperature of over 54°C. (CN111-A1 is below 1.17 volts.)
E-09	The thermistor is open, or related connectors are not connected. (The signal level between CN111-A1 and GND is over 4.9 volts.)

2.6 PAPER MISFEED DETECTION

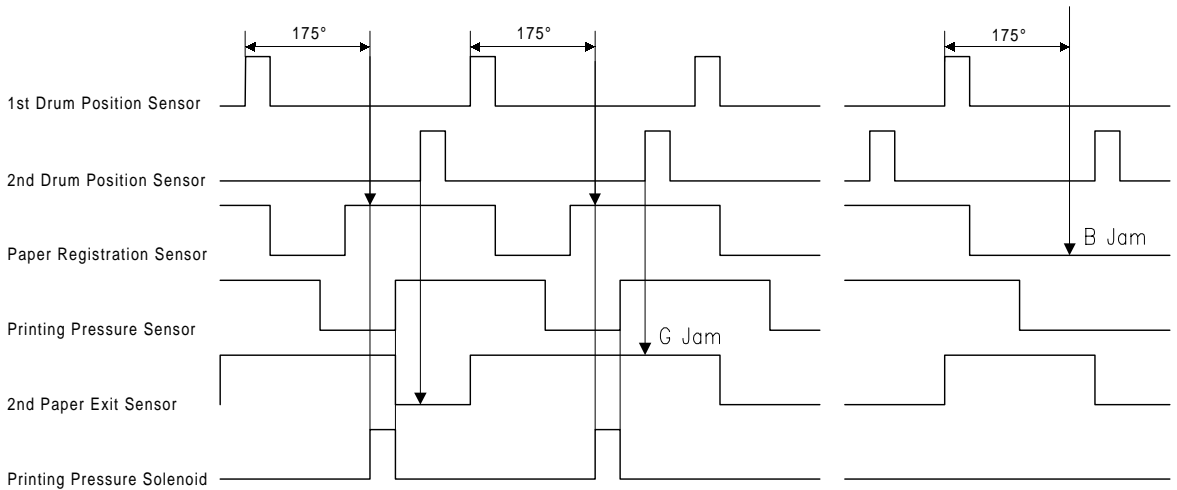

C228D510.WMF

- [a] When the drum has rotated 175° after activating the 1st drum position sensor, if the paper registration sensor is still OFF, a paper misfeed (Location B jam) is detected.
- [b] When the 2nd drum position sensor turns on, if the 2nd paper exit sensor remains ON, a paper misfeed (Location G jam) is detected.

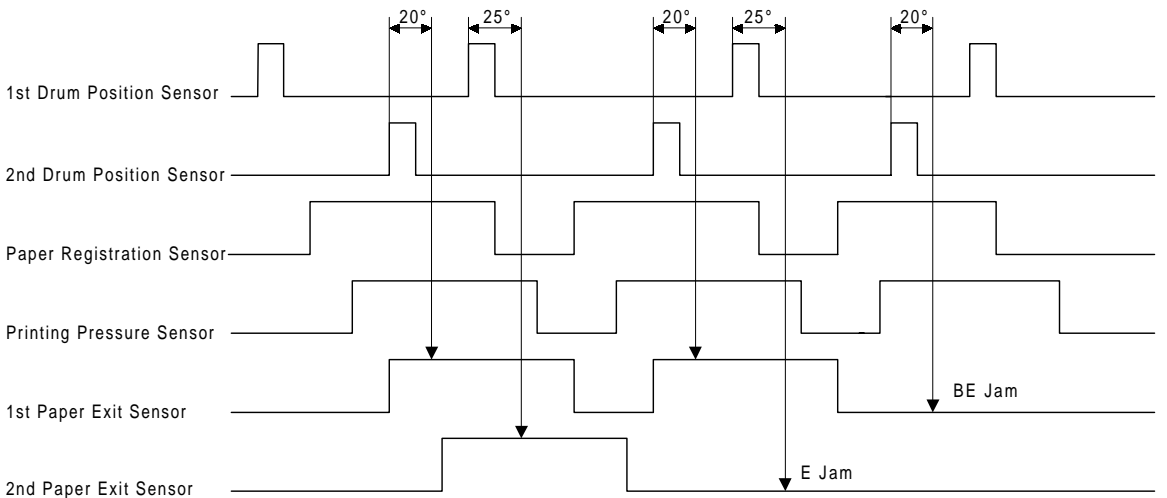

C228D511.WMF

- [c] When the drum has rotated 20° after activating the 2nd drum position sensor, if the 1st paper exit sensor is still OFF, a paper misfeed (Location BE jam) is detected.
- [d] When the drum has rotated 25° after activating the 1st drum position sensor, if the 2nd paper exit sensor is still OFF, a paper misfeed (Location E jam) is detected.

Detailed Descriptions

SECTION 3
INSTALLATION PROCEDURE

3. INSTALLATION

3.1 INSTALLATION REQUIREMENTS

3.1.1 OPTIMUM ENVIRONMENTAL CONDITIONS

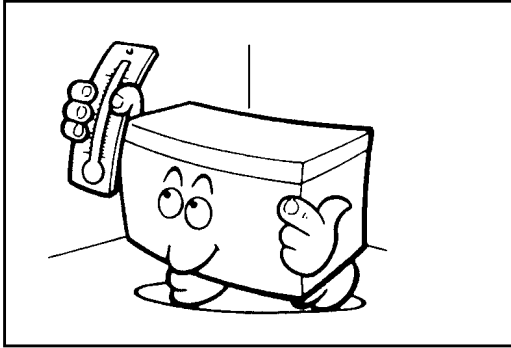

C2231518.PCX

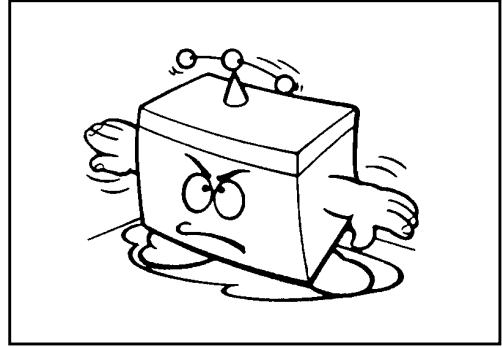

C2231519.PCX

Temperature — 10 to 30°C
(50 to 86°F)

Humidity — 20 to 90 % RH

On a strong and level base.

The machine must be level within 5 mm (13/64") both front to rear and left to right.

3.1.2 ENVIRONMENTS TO AVOID

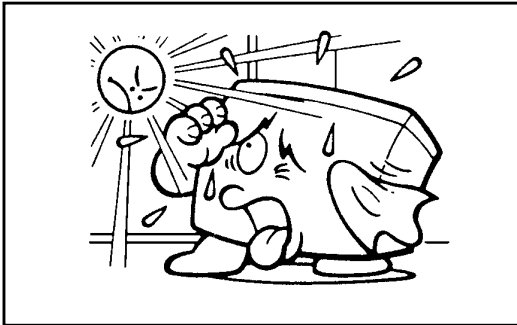

C223I520.PCX

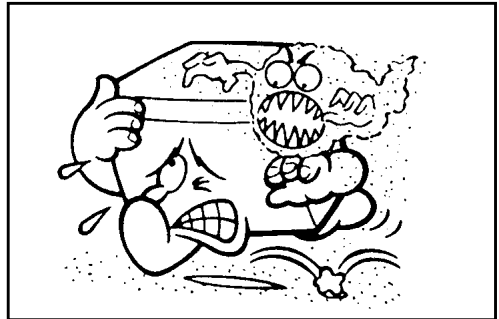

C223I521.PCX

Locations exposed to direct sunlight or strong light (more than 1,500 lux).

Dusty areas.

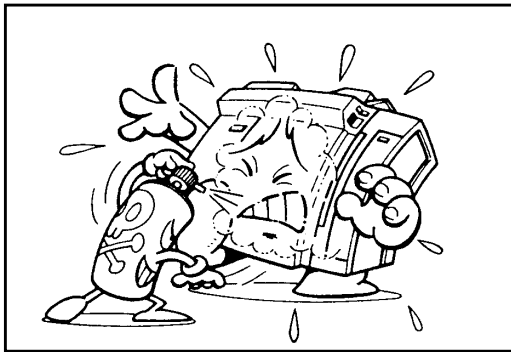

C223I523.PCX

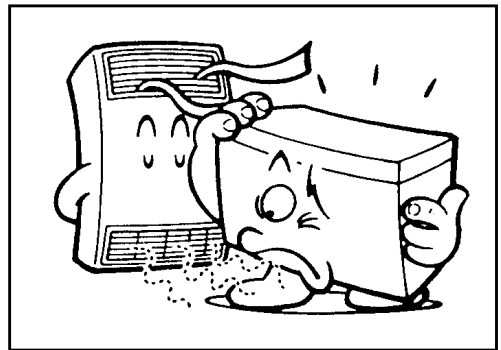

C223I525.PCX

Areas with corrosive gases.

Locations directly exposed to cool air from an air conditioner or reflected heat from a space heater. (Sudden temperature changes from low to high or vice versa may cause condensation within the machine.)

3.1.3 POWER CONNECTION

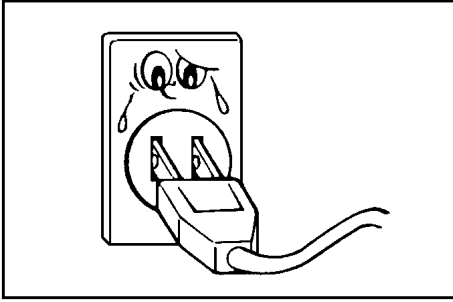

C223I524.PCX

Securely connect the power cord to a power source.

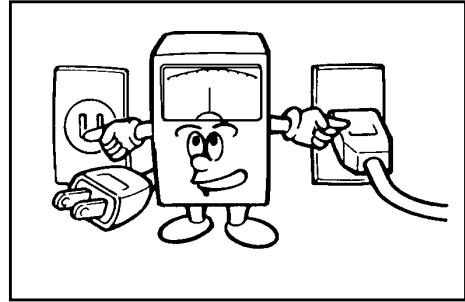

C223I516.PCX

Voltage must not fluctuate more than 10%.

Make sure that the wall outlet is near the machine and easily accessible.

Make sure the plug is firmly inserted in the outlet.

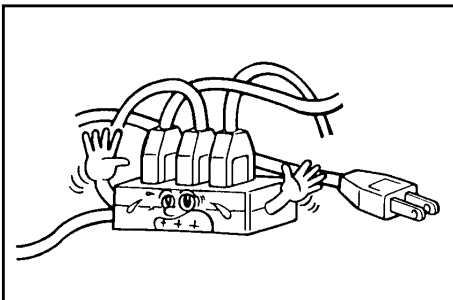

C223I515.PCX

Avoid multiwiring.

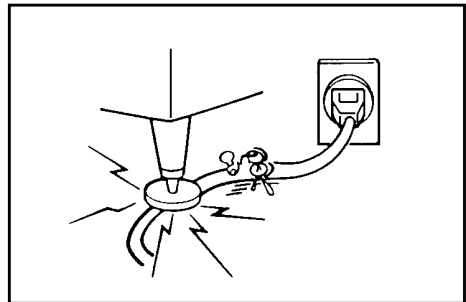

C223I517.PCX

Do not pinch the power cord.

3.1.4 ACCESS TO THE MACHINE

Place the machine near a power source, providing clearance as shown below.

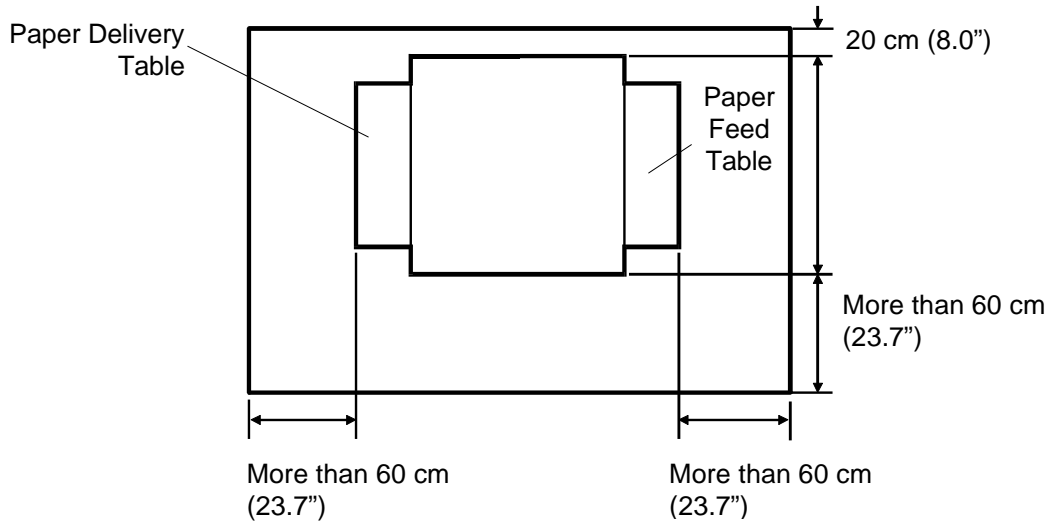

C223I526.WMF

3.2 ACCESSORY CHECK

Make sure that you have the following accessories.

1. Operating Instructions (except for -27 models)
2. NECR (-17, -27 models only)
3. End Plate Prop
4. Decal - Mode
5. Decal - Key Top Cover (OEM machines only)
6. Model Name Plate (OEM machines only)
7. Decal - Master Set (-27 models only)

3.3 INSTALLATION PROCEDURE

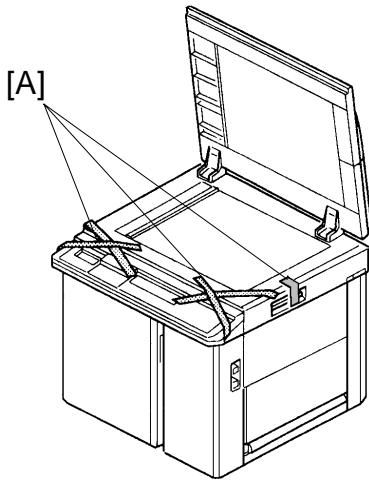

C223I500.PCX

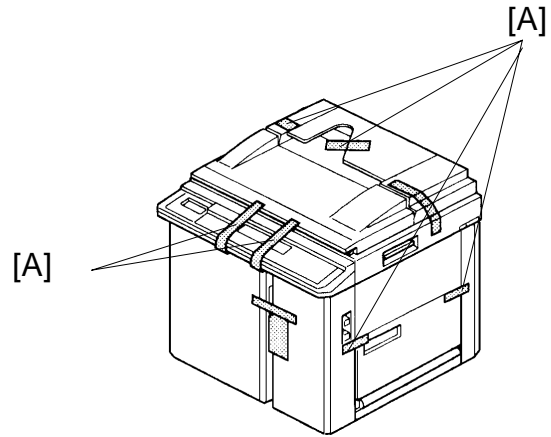

C223I501.PCX

⚠ CAUTION

Do not hold the scanner unit when pushing the machine or the scanner unit safety switch may be damaged.

1. Place the machine on the table.

NOTE: The screw holes in the bottom plate of the machine must line up with the screw holes in the table.

2. Remove the strips of tape [A] securing the covers and units shown above.

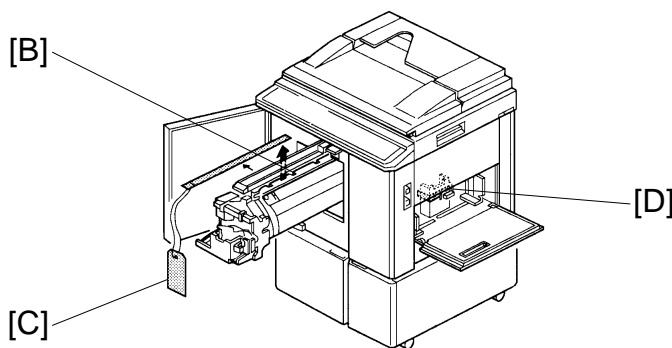

C223I502.PCX

3. Open the front door and slide out the drum unit [B].
4. Open the master clamper and remove the clamp [C].
5. Open the paper feed table and remove the cardboard cover [D] protecting the paper feed roller.

6. Slide the scanner unit to the left (as seen from the operation side) and remove the two strips of tape securing the master box.

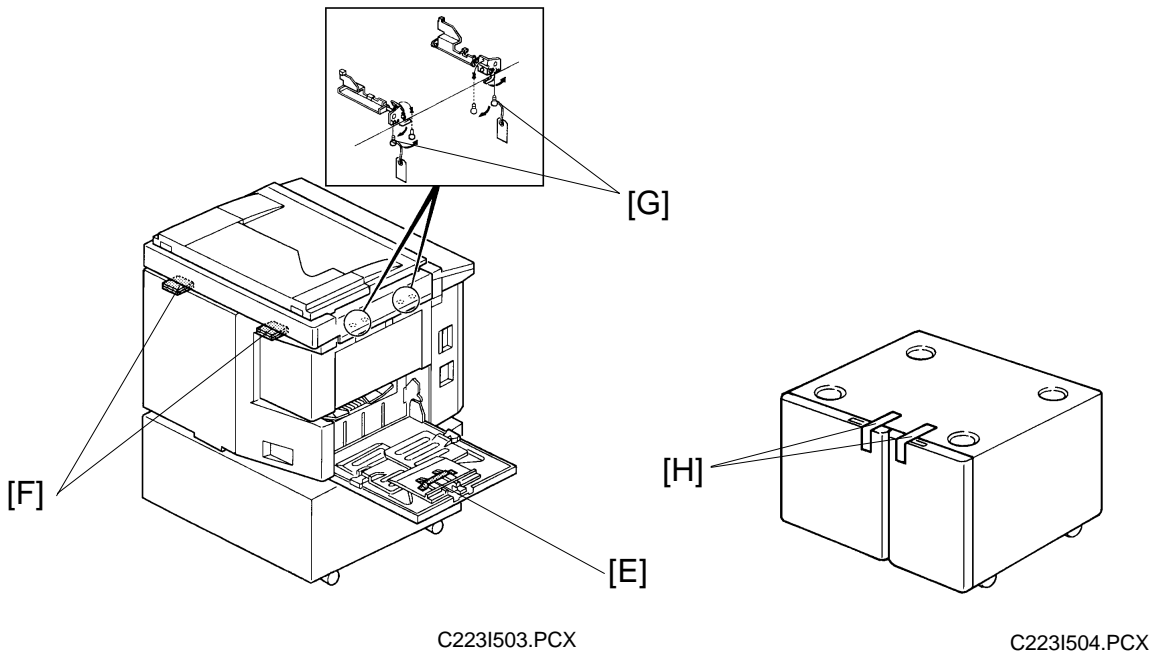

7. Open the paper delivery table and remove the strip of tape [E] protecting the end fence.
8. Remove the cardboard [F] under the scanner unit.
9. Open the scanner unit and change the position of screws [G] from the transport position to the operating position.
10. Open the doors (2 strips of tape [H]) of the optional table and take out the plastic bag containing 2 screws.

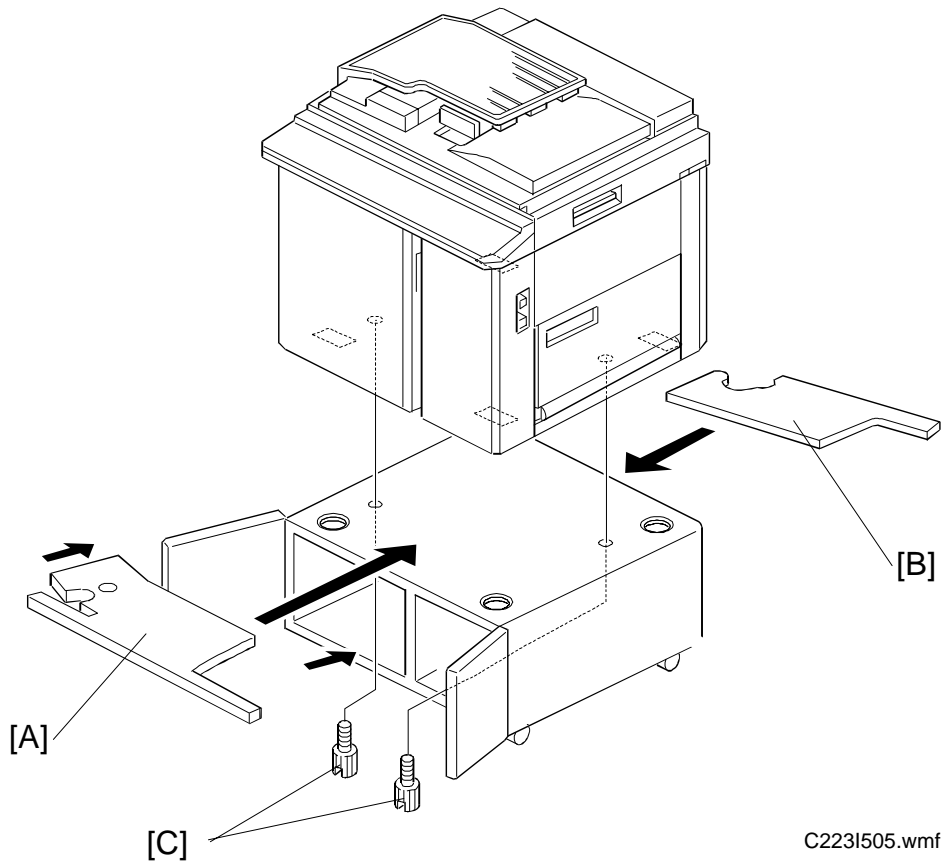

C2231505.wmf

11. Raise the front side of the machine and position the base pad [A] under the machine. Then raise the rear side of the machine and position the other base pad [B] under the machine.
12. Secure the machine to the table with the two screws [C] packed with the table.

13. Open the paper feed table [A] and neatly stack some printing paper on the table.
14. Slide the paper feed side plates [B] gently up against the paper stack.

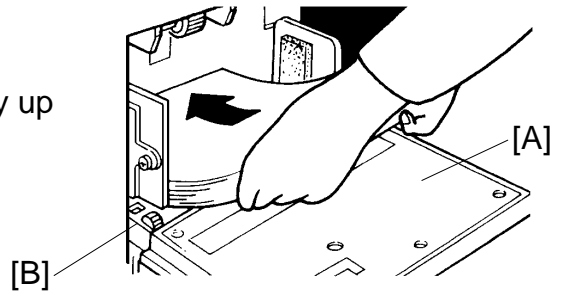

C223I506.PCX

15. Open the paper delivery table [C] and adjust the position of the end plate [D] and the side plates [E] to match the printing paper size. Refer to the paper size scale on the table.

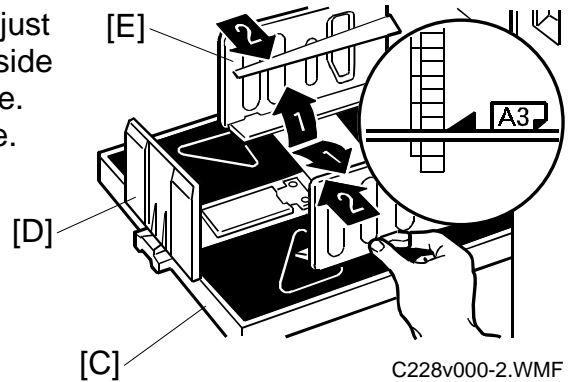

C228v000-2.WMF

16. Install the ink cartridge [F].
 - 1) Open the front door and lower the ink holder [G].
 - 2) Remove the ink cartridge cap.
 - 3) Insert the ink cartridge in the ink holder and raise the ink holder to the original position.
 - 4) Close the front door.

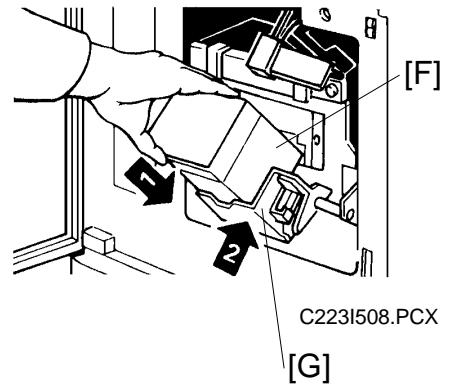

C223I508.PCX

17. Slide the scanner unit all the way to the left, and take the master spools [H] out.

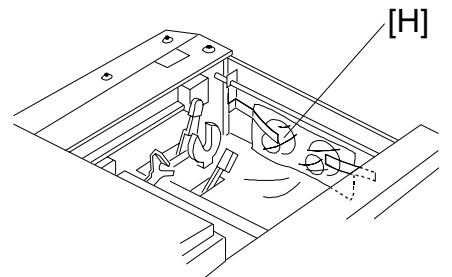

C223I514.wmf

Installation

18. Install the master roll.

- 1) Take out the master roll from the plastic bag.

NOTE:

- Firmly grasp the master roll since it is very slippery.
- Do not remove the strip of the tape holding the master roll till step 5 below.

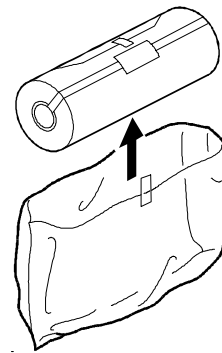

C2281500.WMF

- 2) Attach a spool [A] to each end of the master roll [B].

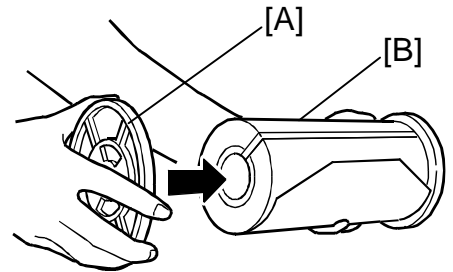

C228V002-2.WMF

- 3) Push the pressure release lever [C] to the left.
- 4) Set the master roll in the machine as shown in the illustration.

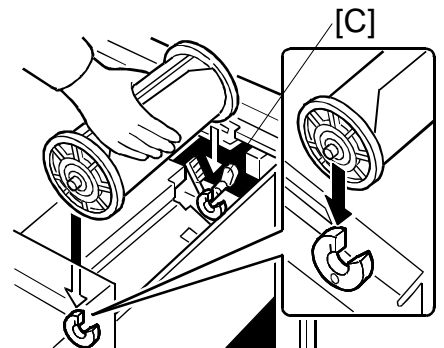

C2281501.PCX

- 5) Remove the tape holding the master roll as shown to the right.

NOTE:

- Hold the spools by hand to remove the tape easier.

- It is better to remove the tape completely, but leave any parts that remain on the spools or in the core.

- 6) Insert the leading edge of the master roll under the platen roller.
- 7) Return the pressure release lever to the original position.
- 8) Plug in the power cord and turn on the main switch.
- 9) Press the master cut button.
- 10) Open the master box cover and remove the cut strip of master paper.

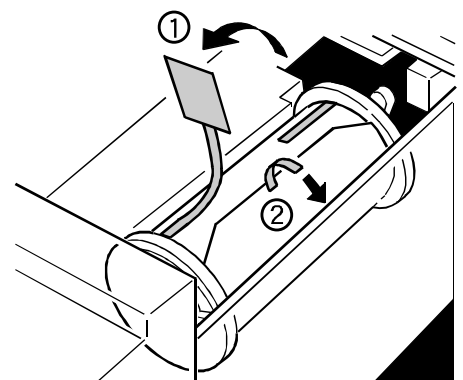

C2281502.WMF

NOTE: Check that the paper on the master roll is not bent or creased.

- 11) Close the scanner unit.

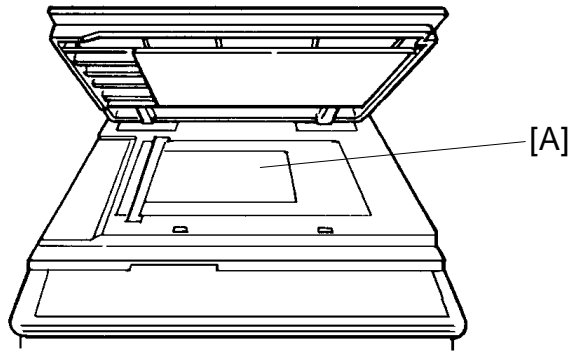

C223I512.PCX

19. Idle the machine to distribute ink on the drum.
 - 1) Press the Reset key while holding down the "0" key on the operation panel.
 - 2) If  blinks on the operation panel when the machine stops, press the Reset key again.
20. Make some test prints to check the machine.
 - 1) Raise the platen cover and place an original face down on the exposure glass [A]. Make sure the original is flush with the left scale and aligned with the proper paper size marks.
 - 2) Press the Master Making key.
 - 3) Select the lowest print speed (1) with the Speed key and press the Print Start key. Make prints at this speed until the print image density stabilizes.

- NOTE:**
- 1) Usually, about 30 prints need to be made before the image fully stabilizes.
 - 2) Check the image quality after the print image density is stabilized.

21. If necessary, change the language for the LCD guidance as follows:
- 1) Turn the main switch off and unplug the machine.
 - 2) Remove the right front cover (4 screws).
 - 3) Change the DIPSW 102-1, 2, 3 settings. The following table shows the setting for each language.

DPS102			LCD Display
1	2	3	
ON	ON	OFF	English (Default)
OFF	OFF	ON	German
ON	OFF	ON	French
OFF	ON	ON	Spanish
ON	ON	ON	Italian

- 4) Reinstall the right front cover (4 screws).

SECTION 4
SERVICE TABLES

4. SERVICE TABLES

4.1 SERVICE REMARKS

1. If a circuit breaker or a fuse opens, check and remove the cause of the overcurrent before resetting the breaker or replacing the fuse.
2. If the thermal head or the power supply unit is replaced, thermal head voltage adjustment is required.
3. Do not touch the edge of the cutter blade with bare hands.
4. Be careful not to drop the master eject unit when removing the eject unit guide shaft.
5. If the paper feed guide plate is removed, make sure that the guide plates do not touch the lower second feed roller when putting back the guide.
6. When putting back the lower separation roller, make sure that the front and rear separation levers move smoothly.
7. If the slowest speed is faster than 60 rpm, the sorter cannot keep up with the machine and a TS sorter jam might occur.
8. Do not energize the master feed and master eject clamber solenoids for longer than 10 seconds.
9. When adjusting the ink roller gap, check the gap at the right, center, and left positions.
10. The ink detection adjustment should be made under normal conditions (20 C/65%RH).
11. When removing the pressure cam drive gear, do not loosen the two deeply recessed bolts.
12. If the main drive belt has been removed, check the relationships between the drum drive gear, printing pressure cam, and the paper feed cams after replacing the belt. Adjust if necessary.
13. Do not keep on pressing the Image Position key if the image position sensor is broken or removed. The plastic gears between the metal gears may break.

4.2 SERVICE TABLES

4.2.1 MAINTENANCE TABLES

Lubrication Points

Lubricate after removing adhering ink and paper dust at yearly intervals.

Section	Lubrication Point	Type	Location
Drive	Speed Reduction Gears of the Main Motor	Grease (Shell Albania No.2)	(Fig.1- E)
	Gears of the Drum Drive Shaft		On the inside and outside of the frame (Fig.1- B)
Image Positioning	Spiral Track of the Cam Gear		(Fig.1- K)
Paper Feed	Paper Feed Sector Gear		(Fig.1- J)
	Second Feed Sector Gear		(Fig.1- F)
	Gear of the Paper Feed Cam Shaft		(Fig.1- A)
	Paper Table Slide Groove		Both front and rear (Fig.1- H)
	Paper Table Drive Gear		(Fig.1- G)
	Bearings for the Upper Separation Roller Shaft	Motor oil (SAE No.20)	(Fig.1- I)
	Bearings for the Paper Feed Roller Shaft		(Fig.2- L)
Drum	Drum Drive Gear	Grease (Shell Albania No. 2)	(Fig.3- N)
	Master Clamper Sector Gear		(Fig.3- O)
	Master Clamper Pinion Gear		(Fig.3- P)
	Ink Pump Drive Gear		(Fig.3- M)
Printing Pressure	Between Printing Pressure Arm [Q] and Printing Pressure Stay [Q']		Both front and rear (Fig.4- Q)
	Pressure Spring Link		(Fig.1- C)
Master Eject	Master Pressure Plate Grooves	Grease (Shell Albania No. 2)	Both front and rear (Fig.5- S)
	Rounded Ends of the Master Pressure Plate Drive Arms		(Fig.5- R)
Paper Exit	Air Pump Drive Gears		(Fig. 6-T)
	Inside of the Air Pump Piston	Grease (Mobil Ep-1)	(Fig. 6-U)
ADF	Bearings for the Feed Roller Shaft	Motor oil (SAE No. 20)	Both front and rear (Fig. 7-V)
Others	Edge of Each Cam	Grease (Shell Albania No. 2)	(Fig.1- D)

[Fig1]

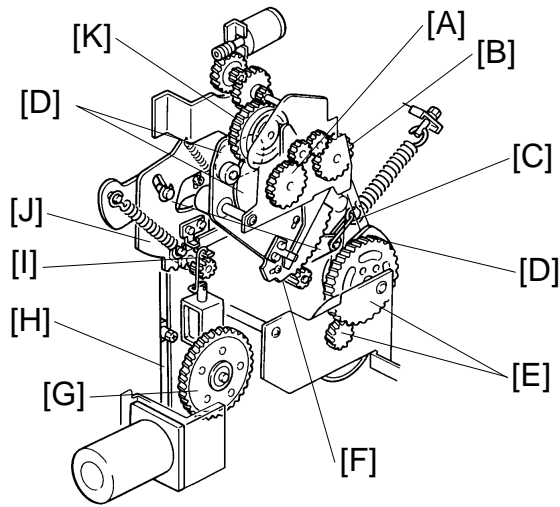

C223M500.PCX

[Fig2]

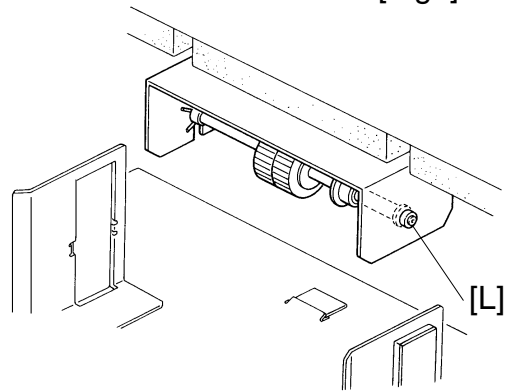

C223M501.PCX

[Fig 3]

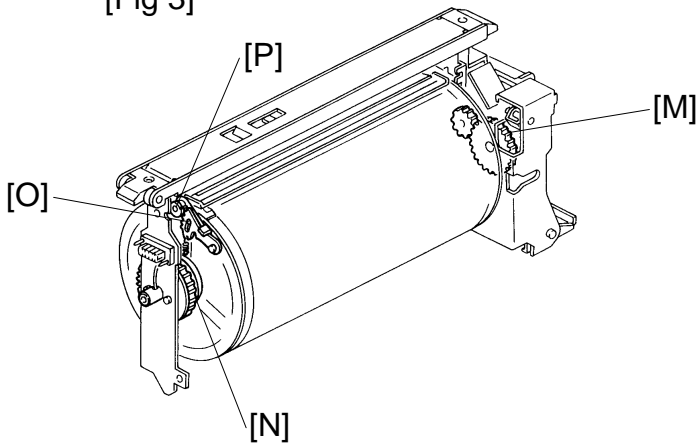

C223M502.PCX

Service
Tables

[Fig 4]

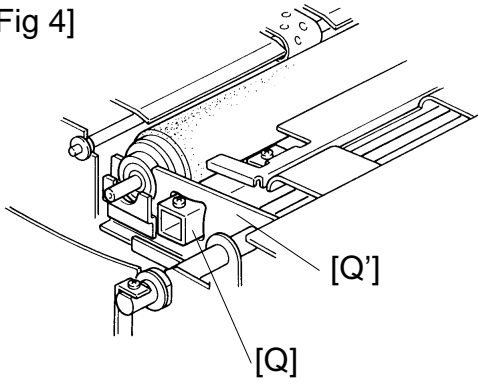

C223M503.PCX

[Fig 5]

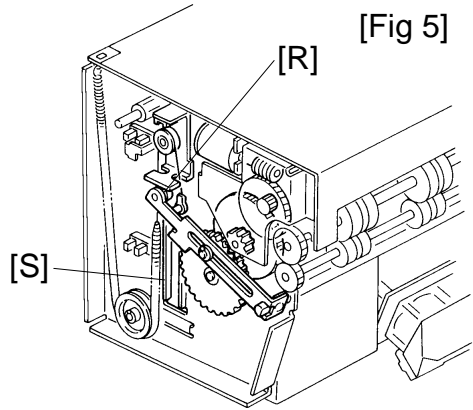

C223M504.PCX

[Fig 6]

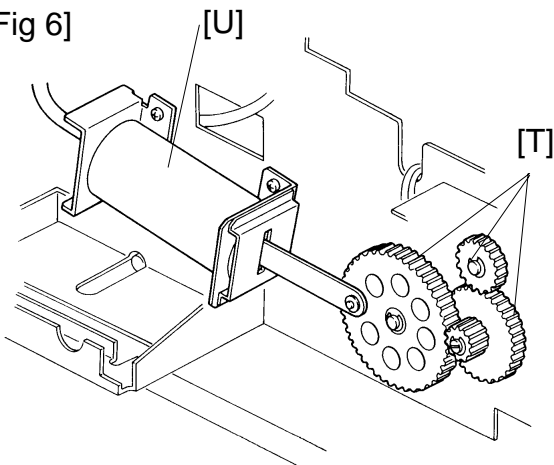

C223M509.PCX

[Fig 7]

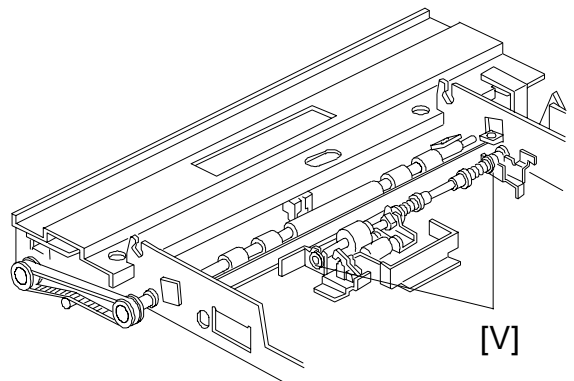

C223M510.WMF

User's Maintenance

Advise the customer to clean each item regularly. Clean the following items at every EM call if necessary.

Section	Cleaning Point	Cleaner	Interval
Optics	Original Platen Cover	Cloth and water	At every EM call
	Exposure Glass	Cloth and glass cleaner	
Paper Feed	Paper Feed Roller	Cloth and soap and water	
	Paper End Sensor	Dry cloth	
	Paper Length Sensor		
Printing	Press Roller	Cloth and soap and water	
ADF	Original Feed Rollers		

Periodic Inspection (every 6 months)

Section	Item	Standard Procedure
Optics	Original Platen Cover	Wipe off stains using a soft cloth moistened with ethyl alcohol.
	Exposure Glass	Wipe with a dry cloth.
Paper Feed	Paper Feed Roller	Wipe off ink and paper powder using a cloth moistened with ethyl alcohol.
	Upper and Lower Second Feed Rollers	
	Upper and Lower Separation Rollers	
Printing	Press Roller	
ADF	Pick-up Roller Feed Roller Separation Roller	Wipe off paper powder using a cloth moistened with water.

Periodic Inspection (every 12 months)

Section	Item	Standard Procedure
Optics	Back side of the Exposure Glass	Wipe with a dry cloth.
	Mirrors	Use a blower brush.
	Xenon Lamps	Wipe with a dry cloth.
Master Eject	Upper and Lower Master Eject Rollers	Wipe off ink and paper powder using a cloth moistened with ethyl alcohol.
Drum	Inside and outside of the Drum	Wipe off built-up ink and paper powder using a cloth moistened with ethyl alcohol.
	Ink Holder	
Master Making	Platen Roller	Wipe off paper powder using a cloth moistened with water.
Others	First and Second Paper Exit Sensors Master Eject Sensor Drum Master Sensor	Check the performance of all the sensors. Remove stains from the sensors using a dry cloth.

4.2.2 SERVICE CALL CODES

Code	Problem	Possible Causes
Main Body		
E-01	Neither the right nor the left cutter switch turns off within 3 seconds of the cutter motor starting.	1) Drive wire cut 2) Drive section malfunction 3) Defective cutter switch
E-02	Malfunction in the paper table drive section. 1. The paper table lower limit sensor or paper table height sensor does not turn on within 7 seconds. 2. The LCT tray drive motor does not stop within 25 seconds. 3. The upper limit sensor does not turn on within 8 seconds after the LCT cassette bottom plate drive motor starts.	1) Drive worm gear broken 2) Mounting screw of the worm gear broken 3) No power supply
E-04	The temperature of the thermal head is greater than 54°C when the Master Making key is pressed	1) Excessive thermal head temperature 2) Thermistor short
E-05	Malfunction in the image shifting section.	1) Image position sensor connector disconnected 2) Defective image position sensor
E-06	The drum rotation sensor detects an incorrect motor speed.	1) Drum lock 2) No power supply
E-09	The signal level between CN104-A1 and GND is over 4.9 volts.	1) The thermistor is open.
E-10	The CPU detects an abnormality in the pulse signals from the image processing PCB. These pulses determine the energy to be applied to the thermal heating elements.	1) Defective thermistor 2) Related connectors are not.
E-11	Encoder output does not change within 3 seconds of the main switch being turned on or the Clear Mode key being pressed.	1) Defective image position motor 2) No power supply

Code	Problem	Possible Causes
E-12	<ol style="list-style-type: none"> 1. The upper or lower pressure plate sensor remains activated for more than 4 seconds after the pressure plate motor starts turning. 2. The lower pressure plate sensor is not activated within 8 seconds of the pressure plate motor starting to turn even though the upper pressure plate sensor is de-activated. 3. The upper pressure plate sensor is not activated for more than 8 seconds after the pressure plate motor starts to turn even though the lower pressure plate sensor is de-activated. 	Pressure plate drive mechanism malfunction.
E-13	<ol style="list-style-type: none"> 1. During scanner initialization: <ul style="list-style-type: none"> – The home position sensor remains activated for more than 4 seconds. – The home position sensor is not activated within 2 seconds. 2. The home position sensor is not activated within 7 seconds when the scanner returns after finishing making the master or scanning. 	<ol style="list-style-type: none"> 1) Defective home position sensor 2) Scanner motor lock
E-14	EMF sorter communication error.	
Sorters		
E-21	The 1st transport motor speed is abnormal.	<ol style="list-style-type: none"> 1) Defective 1st transport motor 2) Defective 1st transport motor rotation sensor.
E-26	<p>The 1st sorter helical wheel H.P. sensor status does not change even if the bin shift motor drive signal is applied.</p> <p>The bin shift motor rotation sensor status does not change even if the bin shift motor drive signal is applied.</p>	<ol style="list-style-type: none"> 1) Defective bin shift motor 2) Defective helical wheel H.P. sensor 3) Defective bin shift motor rotation sensor
E-27	The 1st sorter jogger bar H.P. sensor status does not change even if the jogger bar motor drive signal is applied.	<ol style="list-style-type: none"> 1) Defective jogger bar motor 2) Defective jogger bar H.P. sensor

Code	Problem	Possible Causes
E-28	The 1st sorter staple position switch or staple unit movement switch status does not change even if the staple unit shift motor drive signal is applied.	1) Defective staple unit shift motor 2) Defective jogger bar H.P. sensor 3) Defective staple unit movement switch
E-29	The 1st transport sort mode position sensor or the 1st transport non-sort mode position sensor status does not change even if the delivery table motor drive signal is applied.	1) Defective 1st transport sort mode position sensor 2) Defective 1st transport non-sort position sensor 3) Defective delivery table motor
E-34	The 2nd transport motor rotation sensor speed is abnormal.	1) Defective 2nd transport motor 2) Defective 2nd transport motor rotation sensor
E-36	The 2nd sorter helical wheel H.P. sensor status does not change even if the bin shift motor drive signal is applied. The bin shift motor rotation sensor status does not change even if the bin shift motor drive signal is applied.	1) Defective bin shift motor 2) Defective helical wheel H.P. sensor 3) Defective bin shift motor rotation sensor
E-37	The 2nd sorter jogger bar H.P. sensor status does not change even if the jogger bar motor drive signal is applied.	1) Defective jogger bar motor 2) Defective jogger bar H.P. sensor
E-38	The 2nd sorter staple position sensor or staple unit movement sensor status does not change even if the staple unit shift motor drive signal is applied.	1) Defective staple unit shift motor 2) Defective jogger bar H.P. sensor 3) Defective staple unit movement switch

Service Tables

4.2.3 DIP SWITCHES, LEDS, VRS, TPS (ON THE MAIN CONTROL PCB)

DIP Switches

DIP Switch	Function	Remarks
DIP SW101	Do not use.	Must be off at all times.

DPS 102			LCD Display
1	2	3	
ON	ON	OFF	English
OFF	OFF	ON	German
ON	OFF	ON	French
OFF	ON	ON	Spanish
ON	ON	ON	Italian
OFF	OFF	OFF	For Japanese Machines
ON	OFF	OFF	
OFF	ON	OFF	

DPS 102	ON	OFF
4	DFII (Type 50) Also see SP8.	DFI
5	Print and master counters increment by two counts when the A3 drum is used (NRG setting). Also, see SP86.	Print and master counters increment by one regardless of the drum size.
6	Inch version	A4 version

NOTE: The DF setting can be changed using SP8. When the memory clear (SP60) is performed, the SP8 setting depends on the DPS102-4 setting. Later, if the SP mode is changed but not the DPS, the SP mode setting takes priority. This note also applies to DPS 102-5.

Photodiodes

LED	Component	Remarks
LED101	1st Paper Exit Sensor	When paper is detected, the LED lights.
LED102	Drum Master Sensor	When a master is on the drum, the LED lights.
LED103	2nd Paper Exit Sensor	When paper is detected, the LED lights.
LED104	Master Eject Sensor	When a master is under the master eject sensor, the LED lights.
LED105	Ink Detection	When ink is present, the LED lights.
LED106	Main Motor	When the main motor turns on, the LED lights.

VRs

VR	Function
VR101	1st Paper Exit Sensor Adjustment
VR102	Drum Master Sensor Adjustment
VR103	2nd Paper Exit Sensor Adjustment
VR104	Master Eject Sensor Adjustment
VR105	Adjustment for Drum Speed 5 (120 rpm)
VR106	Adjustment for Drum Speed 1 (60 rpm)

TPs

TP	Function
TP101	1st Paper Exit Sensor Voltage
TP102	Drum Master Sensor Voltage
TP103	2nd Paper Exit Sensor Voltage
TP104	Master Eject Sensor Voltage
TP105	Ink Detection Voltage
TP106	Drum Rotation Sensor Voltage
TP107	GND

4.2.4 EXPECTED LIFE OF PARTS

Section	Part Description	Expected Life
Scanner	Xenon Lamp	15,000 originals
Master Feed/Master Making	Thermal Head	30,000 masters
	Reverse Roller	30,000 masters
	Platen Roller	30,000 masters
	Upper Master Feed Roller	1 year or 30,000 masters
Drum	Drum Cloth Screen	2 years or 1,200,000 prints
Paper Feed	Paper Feed Rubber Side Plate	2 years or 1,200,000 prints
	Paper Feed Roller	6 months or 300,000 prints
	Upper Separation Roller	1 year or 600,000 prints
	Lower Separation Roller	2,000,000 prints
	2nd Feed Roller Brake Belt	1,000,000 prints
	2nd Feed Roller Gear	1,000,000 prints
	Separation Plate	1 year or 600,000 prints
Printing	Press Roller	2 years or 1,200,000 prints
Delivery	Transport Belt	2 years or 1,200,000 prints

4.2.5 SPECIAL TOOLS

Description	Part Number
Test Chart R-21	99992131
Resolution Chart	A0129110
Drum Gauge	C2009001
Image Shifting Gauge	C2009002

4.3 SERVICE PROGRAM MODE

4.3.1 SERVICE PROGRAM MODE OPERATION

The service program (SP) mode is used to check electrical data, change modes, or change adjustment values.

Service Program Mode Access Procedure (for engineers)

All service program modes can be accessed with this procedure.

1. Press the following keys on the operation panel in the following order:

Case 1:

- a) Clear Modes key
- b) Clear key
- c) Combine 2 Originals key
- d) Enter key

Case 2:

- a) Turn off the power switch
- b) Press the Enter key, Stop key, and Clear key simultaneously
- c) Turn on the power

2. The following is displayed on the LCD when the SP mode is accessed.

SP—MODE
PROGRAM No. 0

3. Using the number keys, enter the desired SP mode number (listed in the service program table.)

NOTE: The SP mode number can be shifted up or down by pressing the Zoom key ("+" or "-").

4. To cancel the SP mode, press the Clear Modes key.

Service Program Mode Access Procedure (for users)

This procedure allows users to access only the service program modes that are marked with an asterisk in the service program table.

1. Press the following keys on the operation panel in the following order:
 - a) Clear Modes key
 - b) Clear key
 - c) Enter key
2. The following is displayed on the LCD when the SP mode is accessed.

SP—MODE
PROGRAM No. 0

3. Using the number keys, enter the desired SP mode number (listed in the service program table).
4. To cancel the SP mode, press the Clear Modes key.

Change Adjustment Values or Modes

1. After entering the desired SP mode number, press the Enter key. The current value or mode will be displayed on the LCD (at the end of the second line).
2. Enter the desired value or mode using the number keys (listed in the service program table).
Use the Memory/Class key to toggle between + and -.
3. Press the Enter key to store the desired value or mode.
4. To cancel the SP mode, press the Clear Modes key.

4.3.2 SERVICE PROGRAM TABLE

*: Accessible by a customer<_>** : Can be registered in CS mode

♥: A4 version ♦: LT version

No.	Display	Function	Data	Factory Setting	Comments
1	On line	Enables On Line key operation.	0: No 1: Yes	0	
2	FDC Type 10	Used only in Japan	0: No 1: Yes	0	Keep at 0.
3	Key Counter	Enables key counter operation.	0: No 1: Yes	0	
4	Key Card	Used only in Japan.	0: No 1: Yes	0	
5	EMF Sorter	Selects the number of sorters.	0: No sorters 1, 2, 3, 4, or 5: Sorters present	0	Input 1 to 5 to indicate the number of sorters.
7-1	DS/TS Sorter	Enables TS20A/B operation.	0: No 1: Yes	0	If "1" is selected in 7-1, the machine goes to Auto Reset Time setting mode.
7-2	Auto Reset Time	Specifies the auto reset time.	0: No 1-5: min.	0	
8	ADF Select	Informs the machine if DF Unit Type 50 is installed.	0: DF1 (or no DF) 1: DF2 (type 50)	0	
*10.	Min. Print	Limits the minimum print quantity that can be entered.	0 to 9999	0	
*11	Max. Print	Limits the maximum print quantity that can be entered.	0 to 9999	9999	
*12	♥: A4 → A3 Mag. Ratio ♦: HLT → LG Mag. Ratio	Adjusts the fixed magnification ratio. ♥: From A4 to A3 ♦: From 51/2" x 81/2" to 81/2" x 14"	50 to 200%	♥: 141% ♦: 155%	
*13	♥: A4 → B4 Mag. Ratio ♦: LT → DLT Mag. Ratio	Adjusts the fixed magnification ratio. ♥: From A4 to B4 ♦: From 51/2" x 81/2" to 11" x 17"	50 to 200%	♥: 122% ♦: 129%	
*14	♥: B4 → A3 Mag. Ratio ♦: LG → DLT Mag. Ratio	Adjusts the fixed magnification ratio. ♥: From B4 to A3 ♦: From 81/2" x 14" to 11" x 17"	50 to 200%	♥: 115% ♦: 121%	
*15	Full Size	Adjusts the full size magnification ratio.	50 to 200%	100%	

No.	Display	Function	Data	Factory Setting	Comments
*16	Page Margin	Adjusts the create margin magnification ratio.	50 to 200%	93%	
*17	♥: A3 → B4 Mag. Ratio ♦: LG → LT Mag. Ratio	Adjusts the fixed magnification ratio. ♥: From A3 to B4 ♦: From 81/2" x 14" to 81/2" x 11"	50 to 200%	♥: 87% ♦: 77%	
*18	♥: B4 → A4 Mag. Ratio ♦: ** → LT Mag. Ratio	Adjusts the fixed magnification ratio. ♥: From B4 to A4 ♦: From 11" x 15" to 81/2" x 11"	50 to 200%	♥: 82% ♦: 74%	
*19	♥: A3 → A4 Mag. Ratio ♦: DLT → LT Mag. Ratio	Adjusts the fixed magnification ratio. ♥: From A3 to A4 ♦: From 11" x 17" to 81/2" x 11"	50 to 200%	♥: 71% ♦: 65%	
*20	Buzzer On	Turns the beeper ON or OFF	0: No 1: Yes	0	
*21	Prints/Master Cost	Adjusts the cost ratio of masters to prints for accounting purposes.	0 to 50	0	The set number (0 to 50) is automatically added to the key counter each time a master is used.
22	Read Image Area	Not used	-	0	Not used
*23	Online Paper Size	Used only in Japan	0: A6 1: A5	0	Not used
25	Sorter Feed Speed	Determines the transport belt speed in the TS sorter.	0: -20% 1: -15% 2: -10% 3: -5% 4: +5% 5: +10% 6: +15% 7: +20% 8: +25% 9: +30% 10: 0%	10	
26-1	Sorter Priority	Determines the sorter priority.	0: Normal 1: Others	0	
26-2	0: 1st/2nd 1: 2nd/1st 2: 1st 3: 2nd	Determines the sorter priority when "1" is selected in SP26-1.	0: 1st sorter first 1: 2nd sorter first 2: 1st sorter only 3: 2nd sorter only	0	If "2" or "3" is selected, only one sorter is used.

No.	Display	Function	Data	Factory Setting	Comments
27	Auto Staple Off	Specifies whether the staple unit is disabled.	0: Staple mode enabled. 1: Staple mode disabled.	0	
28	Max. Print/Bin	Specifies the sort/stack number limit.	1 to 50 sheets	50	
**29	Pht Bckgrnd Correct	Determines whether the original background correction is done in Photo mode.	0: Correction is not done. 1: Correction is done.	0	
30	Sub Scan Mag. Adjust	Adjusts the sub-scan magnification.	-1.9 to +1.9%	(0)	The factory setting depends on the machine.
31	MTF Level	Adjusts the MTF level.	0: Low 1: Standard 2: High 3: Maximum	1	
32	Image Density Rank	In line mode, adjusts the image density level.	0: Light 1: Standard 2: Dark	1	
33	Lead Edge Margin	Adjusts the lead edge margin.	4 to 10 mm	5 mm	
34	Line/Pht Mode Level	Use to adjust the threshold level for separating line areas and photo areas in the Line/Photo mode.	0: Change the threshold setting 1: Returns the setting to default	0	If "0" is selected in this mode, the machine goes to 34-1.
34-1	Contrast	Select the contrast setting for changing the threshold for line and photo.	0: Standard 1: Light 2: Dark		Depending on the number selected in this mode, the machine goes to 34-1-0, 34-1-2, or 34-1-3.
34-1-0	Std (setting for the Standard tone)	Adjust the threshold level to distinguish line and photo areas for the Standard tone setting in the Line/Photo mode. There are four numbers and each represents the threshold value for an image density. Input the required value for the one that is blinking, then press Enter to move the next one.	Lt: 0 to 63 Std: 0 to 63 Dk: 0 to 63 Dkr: 0 to 63	Lt: 18 Std: 16 Dk: 22 Dkr: 22	If "0" is selected in 34-1, the machine goes to this mode.

No.	Display	Function	Data	Factory Setting	Comments
34-1-1	Lt (setting for the Light tone)	Adjust the threshold level to distinguish line and photo areas for the Light tone setting in the Line/Photo mode.	Lt: 0 to 63 Std: 0 to 63 Dk: 0 to 63 Dkr: 0 to 63	Lt: 16 Std: 14 Dk: 14 Dkr: 14	
34-1-2	Dk (setting for the Dark tone)	Adjust the threshold level to distinguish line and photo areas for the Dark tone setting in the Line/Photo mode.	Lt: 0 to 63 Std: 0 to 63 Dk: 0 to 63 Dkr: 0 to 63	Lt: 8 Std: 10 Dk: 14 Dkr: 14	
35	Head Energy Adjust	Selects normal mode or Economy mode for changing the thermal head energy.	0: Normal mode 1: Economy mode		Depending on the number selected in this mode, the machine goes to 35-1 or 35-2.
35-1	Head Energy Adjust (Normal)	Adjusts the thermal head energy for the normal mode.	0 to -99 (%)	7	
35-2	Head Energy Adjust (Economy)	Adjusts the thermal head energy for the Economy mode.	0 to -99 (%)	30	
36	Sub Scan Mag. Adjust (ADF)	Adjusts the ADF sub-scan magnification.	-1.9 to 1.9 %	0	0.1 % steps
37	Shadow Erase Level	Selects the image mode for adjusting the threshold level for shadow erase.	0: Line 1: Photo 2: Returns the settings to the defaults		If "0" or "1" is selected in this mode, the machine goes to 37-0 or 37-1.
37-0	Line	Adjusts the shadow erase threshold level for Line mode. There are four numbers and each represents the threshold value for an image density. Input the required value for the one that is blinking, then press Enter to move the next one.	Lt: 0 to 63 Std: 0 to 63 Dk: 0 to 63 Dkr: 0 to 63	Lt: 27 Std: 19 Dk: 15 Dkr: 10	
37-1	Contrast (Photo)	Selects the contrast setting for adjusting the threshold level for shadow erase in Photo mode.	0: Standard 1: Light 2: Dark		Depending on the number selected in this mode, the machine goes to 37-1-0, 37-1-1 or 37-1-2.

No.	Display	Function	Data	Factory Setting	Comments
37-1-0	Std (setting for the normal tone)	Adjusts the shadow erase threshold for the Normal contrast setting in Photo mode. There are four numbers and each represents the threshold value for an image density. Input the required value for the one that is blinking, then press Enter to move the next one.	Lt: 0 to 63 Std: 0 to 63 Dk: 0 to 63 Dkr: 0 to 63	Lt: 24 Std: 15 Dk: 11 Dkr: 4	
37-1-1	Lt (setting for the light tone)	Adjusts the shadow erase threshold for the Light Tone contrast setting in Photo mode.	Lt: 0 to 63 Std: 0 to 63 Dk: 0 to 63 Dkr: 0 to 63	Lt: 31 Std: 24 Dk: 15 Dkr: 9	
37-1-2	Dk (setting for the dark tone)	Adjusts the threshold value for shadow erase of the Dark tone contrast in Photo mode.	Lt: 0 to 63 Std: 0 to 63 Dk: 0 to 63 Dkr: 0 to 63	Lt: 12 Std: 7 Dk: 5 Dkr: 2	
38	ADF Scan Line Adjust	Adjusts the ADF scanning start position.	-4.9 to 4.9 mm	0	0.1 mm steps See remarks (1).
39	Image Center Adjustment	Adjusts the center position of copies in the ADF and platen modes.	0: Scanner 1: ADF	0	See remarks (2).
39-0	Image Center Adjustment: Scanner	Adjusts the center position of copies in platen mode.	-4.9 to 4.9 mm	0	0.1 mm steps
39-1	Image Center Adjustment: ADF	Adjusts the center position of copies in ADF mode.	-4.9 to 4.9 mm	0	0.1 mm steps
*40	Original	Specifies the image mode at power-up.	0: Photo 1: Line 2: Line/Photo	1	
*41	Image Density	Specifies the image density at power-up.	0: Light 1: Standard 2: Dark 3: Darker	1	
42	Print Speed	Specifies the printing speed at power-up.	0: 60 rpm 1: 75 rpm 2: 90 rpm 3: 105 rpm 4: 120 rpm	2	
*43	Auto Cycle Mode	Specifies whether Auto Cycle mode is selected at power-up.	0: No 1: Yes	0	

No.	Display	Function	Data	Factory Setting	Comments
*44	Memory/Class Mode	Specifies the initial job memory feature (Memory or Class mode) at power-up.	0: Class 1: Memory	1	
45	Std. Image Position	Specifies the image position at power-up	1: +15 mm 2: +10 mm 3: +5 mm 4: 0 mm 5: -5 mm 6: -10 mm 7: -15 mm 8: -20 mm	4	
*46	Make Up	Specifies the initial make-up background pattern when the Image Make-up mode is selected.	1 to 40 51 to 90 101 to 140 151 to 190	0	0: No background pattern is selected.
47	Contrast	Specifies the initial contrast when the Photo mode is selected.	0: Standard 1: Light 2: Dark	0	
48	Photo	Specifies the initial screen when the Photo mode is selected.	0: Standard 1: Fine 2: Coarse	0	
*50	Directional Mag. Mode	Selects which is used to input directional magnifications: reproduction ratios or vertical and horizontal lengths.	0: Reproduction ratios 1: Vertical and horizontal lengths	0	
*51	Clear Multi Copy	Resets the Combine 2 originals or Combined Print function (if it has been set) after the master making process.	0: No 1: Yes	0	
52	Compress W Start Key	The master compression for the master eject box is carried out always when the Master Making key is pressed.	0: No 1: Yes	0	This mode is to reduce the possibility of slipping off the eject belts.
60	Clear All Memory	Returns all SP modes to the default settings.	0: No 1: Yes	0	
61	Clear Memory / Except SP 30, 36, 38, 39	Returns all SP modes to the default settings except for SP No. 30, 36, 38 and 39	0: No 1: Yes	0	
70	Original Feed Jam (A)	Displays the total number of original jams.		0	

No.	Display	Function	Data	Factory Setting	Comments
71	Paper Feed Jam (B)	Displays the total number of paper feed jams.		0	
72	Paper Wrap Jam (E)/(B)(E)	Displays the total number of times that paper has accidentally wrapped around the drum.		0	
73	Paper Delivery Jam (G)	Displays the total number of paper delivery jams.		0	
74	Master Feed Jam (C)	Displays the total number of master feed jams.		0	
75	Master Delivery Jam (F)	Displays the total number of master delivery jams.		0	
76	Clear Jam Counters	Clears all jam counters.	0: No 1: Yes	0	
77	Last Sorter Jam	Displays the jam code for the last sorter jam.			
**78-1	Letter/Pht Mode [CS]	Select if letter images is to be emphasized in Letter/Photo mode.	0: Standard 1:Emphasize	0	
78-2	Clear/Original	Select if the image mode (letter, photo, or letter/photo) is to be returned to the default setting when finishing the master making.	0: No 1: Yes	0	
**79	Eco/Quality Start	Specifies if Quality Start operation is done for every master making.	0: No 1: Yes	0	If "1" is selected in 79, the machine goes to 79-1.
79-1	Idling Number	Specifies the number of drum rotations for Quality Start.	0 to 10	2	If "0" is selected in SP79, the number of rotations is determined by SP80.

No.	Display	Function	Data	Factory Setting	Comments
*80	Auto Eco/Q Start	Specifies whether Quality Start is done or not. If "Yes" is selected, the machine goes to "Idling No." mode. The idling number can be selected separately corresponding to the machine off time; 0 to 6 hours, 6 to 32 hours, and more than 32 hours.	0: No 1: Yes	1	If "1" is selected in 80, the machine goes to 80-1.
80-1-1	Idling Number (after a 0 to 6 hour interval)	Specifies the drum rotation number for the machine off time 0 to 6 hours.	0 to 10	0	If Enter key is pressed in this mode, the machine goes to 80-1-2.
80-1-2	Idling Number (after a 6 to 32 hour interval)	Specifies the drum rotation number for when the machine was off from 6 to 32 hours.	0 to 10	2	If Enter key is pressed in this mode, the machine goes to 80-1-3.
80-1-3	Idling Number (after an interval of more than 32 hours)	Specifies the drum rotation number for when the machine was off from more than 32 hours.	0 to 10	3	
81	Proof Print No.	Specifies how many trial prints are made after making the master.	0 to 2 sheets	1	
*82-1	Skip Feed No.	Selects the feed interval.	1 to 9	2	1: Normal operation 2 to 9: One sheet fed every two to nine drum rotations
82-2	Long Sheet ?	Specifies whether a long sheet is used. (If "Yes" is selected, paper exit jam detection is not done.)	0: No 1: Yes	0	Displays only when no. 2 to 9 are selected in 82-1.
*83	Auto Reset Time	Specifies the auto reset time.	0: No 1 to 5 min.	0	
**84	Auto Multi-copy	Specifies the initial mode for Multi copy.	0: Normal 1: Auto (Two or four identical images are made if the Master Making key is pressed once.)	0	

No.	Display	Function	Data	Factory Setting	Comments
85	Initial Compression	Specifies whether full master box detection is made at power-up.	0: No 1: Yes	0	
86	A3 Drum 2 Count Up	Specifies whether the counter increments by two counts per print when the A3 drum is used.	0: No 1: Only the master counter 2: Both the master and the copy counter	0 Ricoh, AB Dick 2 NRG	See Remarks (3)
**87	Memory Print	Specifies the printing operation when in Memory mode.	0: Memory 1: Stack	0	See Remarks (4).
**88	Auto Memory/Class	Specifies whether Auto Memory/Class mode is used.	0: No 1: Yes	1	See Remarks (5).
**89	Gray/Tint Mode	Select "Yes" to make a "Tint" image. (If "Tint" mode is selected, the Screen, Contrast, and Image Density keys are not available.)	0: No 1: Yes	0	
90	Thermal Head Test	Selects the background pattern for the copy made in the thermal head test; performs the test.	1 to 40 51 to 90 101 to 140 151 to 190	7	See the Thermal Head Test section.
91	Command Sheet Check	Prints the command sheet image (designated area) together with the original image.	0: No 1: Yes	0	See the Command Sheet Check section.
92	Thermal Paper Mode	Use this mode to test the thermal head.	0: No 1: Yes	0	See Remarks (6)
93	Erase Area Check	Checks the erase area.	0: No 1: Yes	0	See Remarks (7)
95-1	Scanner Free Run	Selects the type of scanner free run.	0: With the lamp off 1: With the lamp on	0	See Remarks (8)
95-2	Scanner Free Run	Carries out the scanner free run. (The speed can be changed: see Remarks (8).)	Start with the Print Start key. Stop with the Stop key.		Displays when pressing # after selecting 0 or 1 in 95-1.
96	ADF Original Feed Check	Carries out the ADF original feed check. (The speed can be changed; see Remarks (9).)	Start with the Print Start key. Stop with the Stop key.		See Remarks (9)

No.	Display	Function	Data	Factory Setting	Comments
98	Economy Count	Displays the total number of masters made in Economy mode.		0	
99	Staple Count	Displays the total number of stapling operations done so far.		0	
100	Multi-copy Count	Displays the total number of masters made in Multi-copy mode.		0	
101	Make Up Count	Displays the total number of masters made in Make-up mode.		0	
102	Make Up Photo Count	Displays the total number of masters made in Make-up Photo mode.		0	
103	Margin Erase Count	Displays the total number of masters made with the Margin Erase key.		0	
104	On line Count	Displays the total number of masters made in On Line mode.		0	
105	Overlay Count	Displays the total number of masters made in Overlay mode.		0	
106	Enlarge Count	Displays the total number of masters made in Fixed Enlargement mode.		0	
107	Reduction Count	Displays the total number of masters made in Fixed Reduction mode.		0	
108	Zoom Count	Displays the total number of masters made in Zoom mode.		0	
109	Directional Mag.	Displays the total number of masters made in Directional Magnification mode.		0	
110	Power On Time	Displays the total amount of time the machine has been turned on.		0	xxxxx Hour xx Minutes xx Seconds

No.	Display	Function	Data	Factory Setting	Comments
111	Total Count	Displays the total number of masters and prints.		0	M: Master count P: Print count
*113	Resettable Count	Used by the customer to display the total number of masters and prints.		0	M: Master count P: Print count
*114	CLR Reset- table Count	Clears the resettable total master/print counters.	0: No 1: Yes	0	
115	ADF Mode Count	Displays the total number of sheets fed in the ADF mode.		0	
116	Scanner Mode Count	Displays the total number of originals set in platen mode.		0	
117	Color Drum Count	Displays the total number of prints when using the color drum.		0	
118	Paper Size Count	Displays the total number of prints made in each paper size. See Remarks (10).		0	Display counters for each paper size by pressing the # key.
119	CLR All Total Count	Clears the following counters: SP Nos. 111, 115, 116, 117, and 118.	0: No 1: Yes	0	
*120-1	User Code Mode	Selects user code mode, and displays the total number of prints made in the User Code mode.	0: No 1: Yes	0	See the user code mode section.
120-2	Auto Reset Time	Selects the auto reset time.	0: Unlimited 1: 3 min. 2: 5 min.	0	Displays only when "Yes" is selected in 120-1.
*121.	UC Count	Displays the total number of masters and prints made by each user code.		0	Press the # key to shift to another user code.
*122	Clear UC Count	Clears every user code counter.	0: No 1: Yes	0	Same as above.
*123	Total UC Count	Displays the total number of masters and prints for up to 20 user codes.		0	
*124	Clear Total UC Count	Clears the total user code counter.	0: No 1: Yes	0	
130	Input Check Mode	Displays the inputs from sensors and switches.			See the input check table.

No.	Display	Function	Data	Factory Setting	Comments
131	Output Check Mode	Turns on the electrical components.			See the output check table.
132	All Indicators ON	Turns on all the indicators on the operation panel.			Press the # key to light all the indicators.
133	Sorter Cleaning Mode	In this mode, one bin shift is carried out when the Print Start key is pressed. First, select the 1st sorter or 2nd sorter.	1: 1st Sorter 2: 2nd Sorter	1	Depending on the number selected in this mode, the machine goes to 133-1 or 133-2.
133-1	Sorter Cleaning Mode (1st Sorter)	1. When the Print Start key is pressed once, the bin returns to the home position. 2. Each time the Print Start key is pressed after this, one bin shift is carried out. When the 20th bin shift is done, the bins return to the home position.			
133-2	Sorter Cleaning Mode (2nd Sorter)	1. When the Print Start key is pressed once, the bin returns to the home position. 2. Each time the Print Start key is pressed after this, one bin shift is carried out. When the 20th bin shift is done, the bins return to the home position.			
135	SN: 1st Paper Exit	Displays the 1st paper exit sensor voltage.			Unit: Volts
136	SN: 2nd Paper Exit	Displays the 2nd paper exit sensor voltage.			Unit: Volts
137	SN: Master Eject	Displays the master eject sensor voltage.			Unit: Volts
138	SN: Drum Master	Displays the drum master sensor voltage.			Unit: Volts
140	Ink Detection	Specifies whether ink detection is done.	0: No 1: Yes	1	
141	Paper Detection	Specifies whether paper end detection is done.	0: No 1: Yes	1	
** 141-1	Size Detection	Specifies whether paper size detection is done or not.	0: Yes 1: No size detection	0	If "0" is selected in this mode, the machine goes to 142-2.

No.	Display	Function	Data	Factory Setting	Comments
141-2	Size Detection OFF?	Specifies whether the paper size indication on the operation panel is erased.	0: No 1: Yes	0	
*143	Orig. Size Detection	Specifies whether original size detection is done.	0: No 1: Yes	1	
145	Drum Mast. Detection	Specifies whether drum master detection is done.	0: No 1: Yes	1	
146	ADF Cover Detection	This mode disables the ADF Cover Sensor.	0: Disabled 1: Enabled	1	
147	Platen Set Detection	This mode disables the ADF Set Sensor.	0: Disabled (the ADF is always set) 1: Enabled	1	
150	Control ROM No.	Displays the ROM part number and the ROM manufacturing date.		P/No.	1994/10/07 = YYYY/MM/DD
151	Machine No.	Displays the machine serial number and the installation date.		0	Input the serial number and the installation date.
152	Service Tel. No.	Input the service representative's telephone number, which is displayed with the service call code.		0	Use the number keys to input the telephone number at installation. Press the Memory/Class key if you wish to add a space between the digits.
153	Last Service Code	Displays the last service call.		0	
*160	♥: Margin Ers. A3 <input type="checkbox"/> ♦: Margin Ers. 11x17 <input type="checkbox"/>	Adjust the margin erase area. ♥: A3 ♦: 11" x 17"	(50 to 307) x (50 to 432) mm	♥: 289 x 416mm ♦: 271 x 428mm	
*161	♥: Margin Ers. B4 <input type="checkbox"/> ♦: Margin Ers. 8.5 x 14	Adjust the margin erase area. ♥: B4 ♦: 8 1/2" x 14"	(50 to 307) x (50 to 432) mm	♥: 249 x 360mm ♦: 208 x 352 mm	
*162	♥: Margin Ers. A4 <input type="checkbox"/> ♦: Margin Ers. 8.5x11 <input type="checkbox"/>	Adjust the margin erase area. ♥: A4 Landscape ♦: 8 1/2" x 11" Landscape	(50 to 307) x (50 to 432) mm	♥: 202 x 293 mm ♦: 208 x 275 mm	

No.	Display	Function	Data	Factory Setting	Comments
*163	♥: Margin Ers. A4 <input type="checkbox"/> ♦: Margin Ers. 8.5x11 <input type="checkbox"/>	Adjust the margin erase area. ♥: A4 Portrait ♦: 8 1/2" x 11" Portrait	(50 to 307) x (50 to 432) mm	♥: 289 x 206 mm ♦: 271 x 212 mm	
*164	♥: Margin Ers. B5 <input type="checkbox"/> ♦: Margin Ers. 5.5x8.5 <input type="checkbox"/>	Adjust the margin erase area. ♥: B5 Landscape ♦: 5 1/2" x 8 1/2" Landscape	(50 to 307) x (50 to 432) mm	♥: 174 x 253 mm ♦: 132 x 212 mm	
*165	♥: Margin Ers. B5 <input type="checkbox"/> ♦: Margin Ers. 5.5x8.5 <input type="checkbox"/>	Adjust the margin erase area. ♥: B5 Portrait ♦: 5 1/2" x 8 1/2" Portrait	(50 to 307) x (50 to 432) mm	♥: 249 x 178 mm ♦: 208 x 136 mm	
*166	♥: Margin Ers. A5 <input type="checkbox"/> ♦: Margin Ers. **1 <input type="checkbox"/>	Adjust the margin erase area. ♥: A5 Landscape ♦: 2" x 2"	(50 to 307) x (50 to 432) mm	♥: 140 x 206 mm ♦: 50x 50 mm	
*167	♥: Margin Ers. A5 <input type="checkbox"/> ♦: Margin Ers. **2 <input type="checkbox"/>	Adjust the margin erase area. ♥: A5 Portrait ♦: 2" x 2"	(50 to 307) x (50 to 432) mm	♥: 202 x 144 mm ♦: 50x 50 mm	
*168	♥: Margin Ers. A6 <input type="checkbox"/> ♦: Margin Ers. **3 <input type="checkbox"/>	Adjust the margin erase area. ♥: A6 Landscape ♦: 2" x 2"	(50 to 307) x (50 to 432) mm	♥: 97x 144 mm ♦: 50x 50 mm	
*169	♥: Margin Ers. A6 <input type="checkbox"/> ♦: Margin Ers. **4 <input type="checkbox"/>	Adjust the margin erase area. ♥: A6 Portrait ♦: 2" x 2"	(50 to 307) x (50 to 432) mm	♥: 140 x 101 mm ♦: 50x 50 mm	
*170	♥: Margin Ers. ** <input type="checkbox"/> ♦: Margin Ers. **5 <input type="checkbox"/>	Adjust the margin erase area. ♥: Others ♦: 2" x 2"	(50 to 307) x (50 to 432) mm	♥: 92x 144 mm ♦: 50x 50 mm	

Remarks

1) SP Mode No. 38 — ADF Scan Line Position

The printing position moves as shown below.

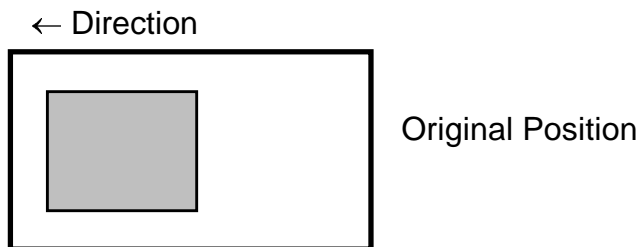

+X: Moves X mm to the left

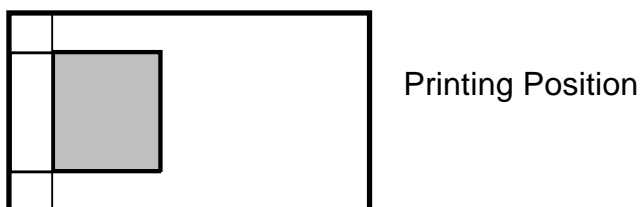

-X: Moves X mm to the right

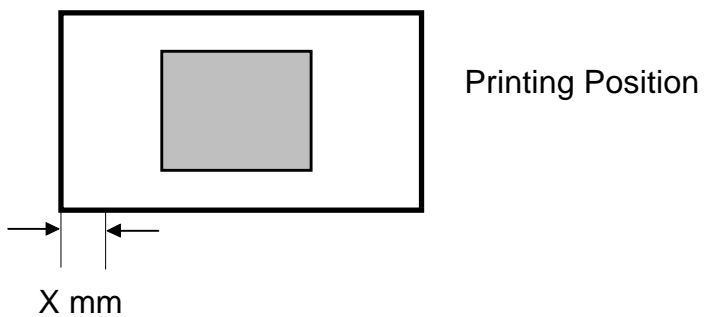

2) SP Mode No. 39 — Image Center Position
The printing position moves as shown below.

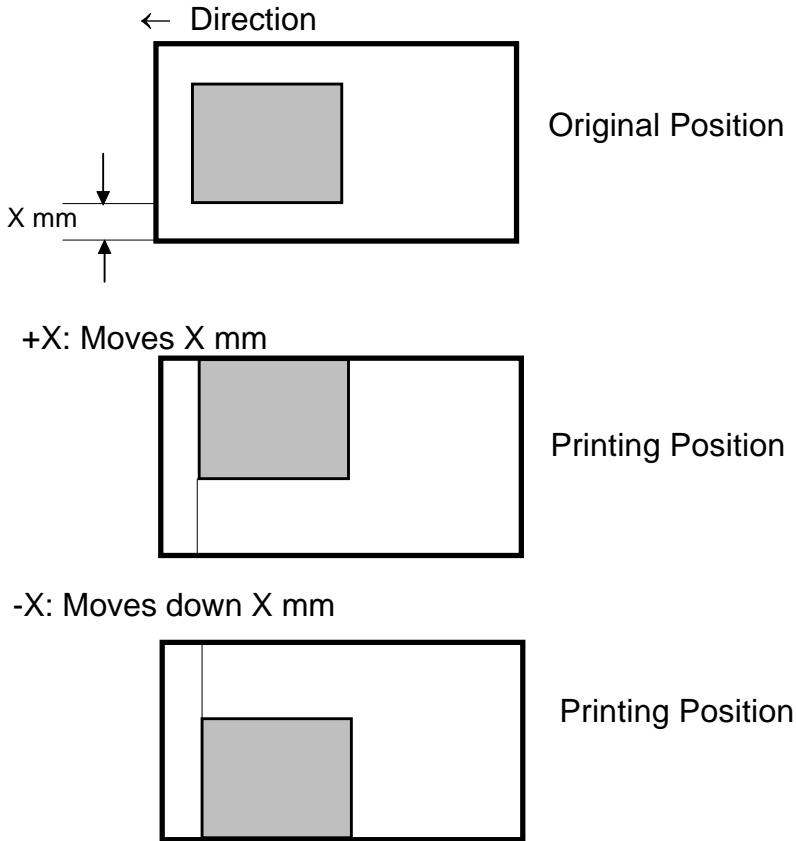

Note: When adjusting the scanner image position input "0" first:

Example) $X = 0.9 \text{ mm} \rightarrow "0", "9",$ and then press the # key.

3) SP Mode No. 86 — A3 Drum 2 Count Up

The counter increment goes up by 2 if an A3 drum is installed, regardless of the size of paper.

The default setting is changed with DIP switch 102-5. See Sub-section 2.3.1. of section 4.

4) SP Mode No. 87 — Memory Print

Normally, in platen mode (when no originals are placed in the ADF), the machine stops when the 1st print job is finished even if the tape marker is installed, so that the next original can be placed. The next printing job starts when the Print Start key is pressed.

If "1" is selected in this mode, after the 1st print job is finished, the tape marker feeds a strip of tape and the next print job starts immediately afterwards.

5) SP Mode No. 88 — Auto Memory/ Class

In Memory/Class mode, the machine normally stops when the first print job is finished if the tape marker is not installed.

If "1" is selected in this mode, the machine stops for a while (this interval is the same as when the tape marker is operating). Then it continues with the next print (or master making) job.

6) SP Mode 92 — Thermal Paper Mode

You can use this mode to test the thermal head.

Place some thermal printer in the plotter face down and change this SP Mode to 1. Place an original on the exposure glass and press the Master Making key. The machine starts printing on the thermal paper without doing the master clamp process.

You can also enable SP Mode 90 and press the Master Making key to test the thermal head without placing an original on the exposure glass.

7) SP Mode 93 — Erase Area Check

This checks the erased area for shadow erase (Center and Edge Margin Erasing). If you make a master and print an image with this mode, the machine makes a background pattern on the area to be erased.

8) SP Mode No. 95 — Scanner Free Run

- It is possible to change the first scanner speed by changing the magnification ratio:
25 to 200 % (Maximum speed = 25 %)
- To start the scanner free run, press the Print Start key after selecting "Lamp On/Off" using the # key.
 Input a magnification ratio if you wish to change the first scanner speed, before you press the Start key. (Factory setting = 25 %)
- To stop the scanner free run, press the Stop key. The scanner returns to home position, then stops.
- The machine does not exit SP mode until the scanner returns to home position correctly.

9) SP Mode No. 96 — ADF Original Feed Check

- It is possible to change the original feed speed by changing the magnification ratio:
25 to 200 % (Maximum speed = 25 %)
- To start original feed, press the Print Start key after placing originals in the ADF.
 Input a magnification ratio if you wish to change the original feed speed, before you press the Start key. The ADF starts feeding until all originals are fed.
- To stop feeding, press the Stop key. The original stops at this moment.
- If the original feed fails, or if the Stop key is pressed, the "A + Jam" indicator turns on.
 If the jammed originals are removed from the ADF, the jam indicator turns off and the failure is reset.
- The machine does not exit SP mode during feeding.

10) SP Mode No. 118 — Print Size Count

- The print size counter indicates the following paper sizes:

A4 version

- A3
- B4
- A4 Landscape
- A4 Portrait
- B5 Landscape
- B5 Portrait
- * (Others)

LT version

- DLT
- LT
- LT Landscape
- LT Portrait
- HLT
- * (Others)

4.3.3 THERMAL HEAD TEST

This function is used to determine which printer component is causing an image problem on the master.

In this mode, the background pattern that is printed covers the entire sheet of paper.

Procedure

1. Place paper on the paper table.

NOTE: To reduce thermal head load, use the smallest paper size possible, i.e. the smallest paper width on which the part with the image problem can be printed.

2. Access SP mode.

3. Input No. 90 and press the Enter key.

NOTE: The factory setting is pattern No. 7. If necessary, input another background pattern with the Number keys.

4. Press the Master Making key (an original is not necessary).

5. Make some prints and check the image.

Assessment

If the printout is normal, a Part A component is defective.

If the printout is abnormal, a Part B component is defective.

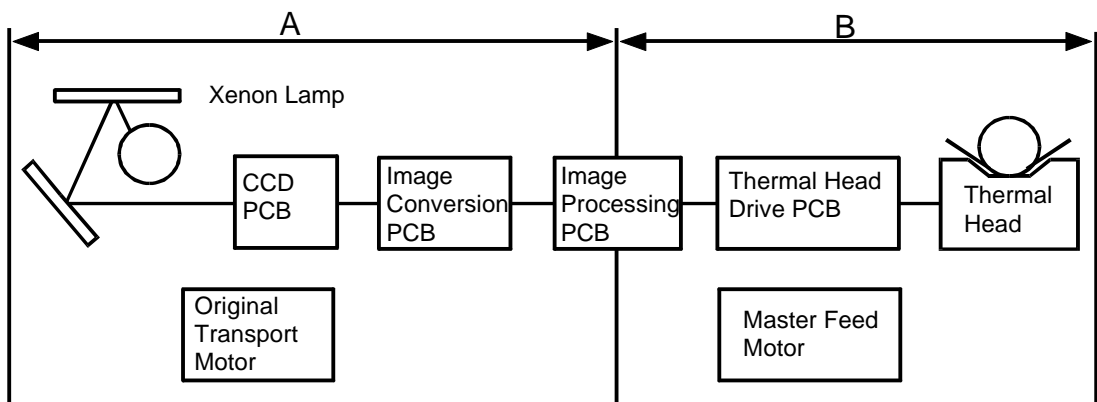

C223M511.WMF

- This mode can be used in combination with SP mode No. 92, Thermal Paper Mode.

4.3.4 COMMAND SHEET CHECK

Normally, Fn 9 or Fn 19 cannot be input in Make-up mode.

By changing the data of SP mode #91 from 0 to 1, Fn 9 or Fn 19 can be input.

Command No.	Display	Function
Fn 9	OVERLAY	Prints both the original image and designated area of the command sheet on the paper.
Fn 19	OVERLAY	

This function is used to check the position of the designated area on the command sheet. It is checked in relation to the original image to make sure that the command sheet is being read correctly.

Procedure

1. Access SP mode.
2. Input 91 and press the Enter key.
3. Input 1 with the number keys and press the Enter key.
4. Press the Clear Modes key to leave SP mode.
5. Place the command sheet and the original on the ADF.
6. Press the Make-up key and input Fn 9 or Fn 19 (these commands have the same function).
7. Input 1 for the undesignated area.
8. Press the Master Making key and then check the print to make sure that the area designated by the command sheet is in the correct position on the original image.

NOTE: 1) Only one command sheet can be stored in memory. If two or more command sheets are read, only the last command sheet is output.
2) Make sure to return the SP mode to its original setting after checking the designated area position.

4.3.5 INPUT/OUTPUT CHECK MODE

This program checks the electrical components. The procedure for accessing the program is as follows:

Input Check Mode Access Procedure

1. Access SP mode. (See the SP mode access procedure.)
2. Enter 130 (SP mode number) with the number keys.
3. Press the Enter key.
4. Enter the desired input number. (See the input check table.)
NOTE: The input number can be shifted up or down by pressing the Zoom key.
5. Press the Enter key.
NOTE: In the input check mode, all image position LEDs and printing speed LEDs turn on when a sensor or switch that is being tested is actuated. A beep will also be heard.
6. Press the Enter key to return the display to the initial input check menu.
7. Press the Clear Modes key to leave SP mode.

Output Check Mode Access Procedure

1. Access SP mode. (See the SP mode access procedure.)
2. Enter 131 (SP mode number) with the number keys.
3. Press the Enter key.
4. Enter the desired output number. (See the output check table.)
NOTE: The output number can be shifted up or down by pressing the Zoom key ("+" or "-").
5. Press the Enter key.
6. Press the Print Start key to turn on the component.
7. Press the Enter key to return the display to the initial output check menu.
8. Press the Clear Modes key to leave the SP mode.

Input Check Table

Code	LCD Display	Component Checked
1.	SN: ADF Cover In- 1	ADF Cover Sensor
2.	SN: 1st Original (ADF) In- 2	Original Set Sensor
3.	SN: 2nd Original (ADF) In- 3	Original Registration Sensor
4.	SN: 3rd Original (ADF) In- 4	Scan Line Sensor
5.	SN: Original Size 0 In- 5	Original Width Sensor - 0
6.	SN: Original Size 1 In- 6	Original Width Sensor - 1
7.	SN: Original Size 2 In- 7	Original Width Sensor - 2
8.	SN: Original Size 3 In- 8	Original Width Sensor - 3
9.	SN: Cassette Size 0 In- 9	Cassette Size Switch - 4
10.	SN: Cassette Size 1 In-10	Cassette Size Switch - 3
11.	SN: Cassette Size 2 In-11	Cassette Size Switch - 2
12.	SN: Cassette Size 3 In-12	Cassette Size Switch - 1
13.	SN: Paper Size 0 In-13	Paper Width Sensor - 0
14.	SN: Paper Size 1 In-14	Paper Width Sensor - 1
15.	SN: Paper Size 2 In-15	Paper Width Sensor - 2
16.	SN: Paper Size 3 In-16	Paper Width Sensor - 3
17.	SN: Paper Size 4 In-17	Paper Length Sensor
18.	SN: Paper End In-18	Paper End Sensor
19.	SW: Paper Table Open In-19	Paper Table Open Switch
20.	SN: Paper Table Low Limit In-20	Paper Table Lower Limit Sensor
21.	SN: Paper Table Height In-21	Paper Table Height Sensor
22.	KEY: Lower Paper Feed Table In-22	Paper Table Down key
23.	SW: Right Cutter In-23	Right Cutter Switch

Code	LCD Display	Component Checked
24.	SW: Left Cutter In-24	Left Cutter Switch
25.	SN: Master Buckle In-25	Master Buckle Sensor
26.	SN: Master End In-26	Master End Sensor
27.	SIG: Ink In-27	When the Ink Detecting Pin detects ink
28.	SIG: Color Drum In-28	When a color drum is installed
29.	SIG: Drum Size 0 In-29	When an A3/DLT or A4/LG drum is installed
30.	SIG: Drum Size 1 In-30	When an A4/LT drum is installed
30.	SIG: Drum Set In-30	When an A4/LT drum is installed
31.	SN: Pressure Plate High Position In-31	Upper Pressure Plate Sensor
32.	SN: Pressure Plate Low Position In-32	Lower Pressure Plate Sensor
33.	SW: Master Eject Box In-33	Master Eject Box Switch
34.	SN: Full Master In-34	Full Master Box Sensor
35.	SN: Printing Pressure In-35	Printing Pressure Sensor
36.	SN: 1st Drum Position In-36	First Drum Position Sensor
37.	SN: 2nd Drum Position In-37	Second Drum Position Sensor
38.	SW: Manual Master Cut In-38	Master Cut Switch
39.	SIG: Key Counter In-39	When a key counter is installed
40.	SIG: Power Supply Temp. Detect In-40	When the power supply unit temperature is over 85 °C
41.	SN: 1st Paper Exit In-41	First Paper Exit Sensor
42.	SN: 2nd Paper Exit In-42	Second Paper Exit Sensor
43.	SN: Master Eject In-43	Master Eject Sensor
44.	SN: Drum Master In-44	Drum Master Sensor
45	SN: Scanner Home Position In-45	Scanner Home Position Sensor

Code	LCD Display	Component Checked
46	SN: Platen Angle (Scanner) In-46	Platen Cover Position Sensor
47	SN: Platen Set (Scanner) In-47	ADF Set Sensor
48	SN: Platen Original (Scanner) In-48	Original Sensor
49	SN: 4th Original (ADF) In-49	Original Exit Sensor
50	SW: Delivery Table Open In-50	Delivery Table Open Switch
51	SN: Paper Registration In-51	Paper Registration Sensor
52	SN: T. Head Position In-52	Thermal Head Pressure Release Sensor
60	SN: Feed Unit Low (1st Sorter) In-60	1st Transport Non-Sort Mode Position Sensor (Sorter)
61	SN: Feed Unit High (1st Sorter) In-60	1st Transport Sort Mode Position Sensor (Sorter)
62	SN: Feed Unit Cover (1st Sorter) In-62	1st Transport Cover Open Switch (Sorter)
63	SN: Safety Switch (1st Sorter) In-63	Staple Cover Open Switch (1st Sorter)
64	SN: Staple Cover (1st Sorter) In-64	Staple Cover Open Switch (1st Sorter)
65	SN: Paper Edge (1st Sorter) In-65	Trailing Edge Sensor (Sorter)
66	SN: Sort Paper (1st Sorter) In-66	1st Transport Sensor (Sorter)
67	SN: Stapler Position (1st Sorter) In-67	Staple Position Switch (1st Sorter)
68	SN: Stapler Unit Move (1st Sorter) In-68	Staple Unit Movement Switch (1st Sorter)
69	SN: Stapler H.P. (1st Sorter) In-69	Staple Home Position Sensor (1st Sorter)
70	SN; Staple End (1st Sorter) In-70	Staple End Sensor (1st Sorter)
71	SN: Jogger Bar H.P. (1st Sorter) In-71	Jogger Bar Home Position Sensor (1st Sorter)
72	SN: Lead Cam H.P. (1st Sorter) In-72	Helical Wheel Position Sensor (1st Sorter)
73	SN: Bin Home Position (1st Sorter) In-73	Bin Unit Home Position Sensor (1st Sorter)
74	SN: Bin Paper (1st Sorter) In-74	Bin/Jam Sensor (1st Sorter)
75	KEY: Stapler (1st Sorter) In-75	Manual Staple Key (1st Sorter)
76	SN: Staple Paper (1st Sorter) In-76	Paper Sensor-Stapler (1st Sorter)

Code	LCD Display	Component Checked
77	SN: Bin Shift MT CLK (1st Sorter) In-77	Bin Shift Motor Rotation Sensor (1st Sorter)
78	SN: Feed Motor CLK1 (1st Sorter) In-78	1st Transport Motor Rotation Sensor (1st Sorter)
79	SN: Feed Motor CLK2 (1st Sorter) In-79	2nd Transport Motor Rotation Sensor (Sorter)
80	SN: Staple Cover (2nd Sorter) In-80	Staple Cover Open Switch (2nd Sorter)
81	SN: Paper Edge (2nd Sorter) In-81	Trailing Edge Sensor (2nd Sorter)
82	SN: Sort Paper (2nd Sorter) In-82	2nd Transport Sensor (Sorter)
83	SN: Stapler Position (2nd Sorter) In-83	Staple Position Switch (2nd Sorter)
84	SN: Stapler Unit Move (2nd Sorter) IN-84	Staple Home Position Sensor (2nd Sorter)
85	SN: Stapler H.P. (2nd Sorter) IN-85	Staple End Sensor (2nd Sorter)
86	SN: Staple End (2nd Sorter) In-86	Staple End Sensor (2nd Sorter)
87	SN: Jogger Bar H.P. (2nd Sorter) In-87	Jogger Bar Home Position Sensor (2nd Sorter)
88	SN: Lead Cam H.P. (2nd Sorter) In-88	Helical Wheel Home Position Sensor (2nd Sorter)
89	SN: Bin Home Position (2nd sorter) In-89	Bin Unit Home Position Sensor (2nd Sorter)
90	SN: Bin Paper (2nd Sorter) In-90	Bin/Jam Sensor (2nd Sorter)
91	KEY: Stapler (2nd Sorter) In-91	Manual Staple Key (2nd Sorter)
92	SN: Stapler Paper (2nd Sorter) In-92	Paper Sensor-Stapler (2nd Sorter)
93	SN: Bin Shift MT .LK (2nd Sorter) In-93	Bin Shift Motor Rotation Sensor (2nd Sorter)
100	SN: Cassette Paper	Cassette Paper End Sensor (LCT)
101	SN: Paper End	Tray Paper Position Sensor (LCT)
102	SN: Paper Position	Tray Paper Position Sensor (LCT)
103	SIG: LCT	CN110 Connection (Should be ON when connected)
104	SN: Low Limit	Tray Lower Limit Sensor (LCT)
105	SN: Paper MAX. Limit	Maximum Paper Load Sensor (LCT)
106	KEY: Lower LCT	Tray Down Switch (LCT)
107	SN: Paper Size 0	Paper Size Sensor 0 (LCT)
108	SN: Paper Size 1	Paper Size Sensor 1 (LCT)
109	SN: Paper Size 2	Paper Size Sensor 2 (LCT)
110	SN: Paper Size 3	Paper Size Sensor 3 (LCT)
111	SN: Paper Size 4	Paper Size Sensor 4 (LCT)
112	SN: LCT Cover	Cover Open Switch (LCT)

Code	LCD Display	Component Checked
113	SIG: Cassette	Cassette Switch (LCT)

Output Check Table

Code	LCD Display	Description
2	MOTOR: ADF Drive Out- 2	Turns on the ADF drive motor.
3	MOTOR: Master Eject Out- 3	Turns on the master eject motor.
4	MOTOR: Pressure Plate Up/Down Out- 4	Turns on the pressure plate up/down motor.
5	MC: Master Reverse Roller Out- 5	Turns on the master reverse roller magnetic clutch.
6	MOTOR: Vacuum Out- 6	Turns on the vacuum fan motor.
7	MOTOR: Air Knife Out- 7	Turns on the air knife motor.
8	SIG: Key Counter Out- 8	Increments the key counter.
9	COUNTER: Master Out- 9	Increments the master counter.
10	COUNTER: Paper Out-10	Increments the total counter.
11	SOL: Paper Separation Release Out-11	Turns on the separation plate release solenoid.
12	SOL: Ink Supply Out-12	Turns on the ink supply solenoid.
13	SOL: Drum Lock Out-13	Turns on the drum lock solenoid.
14	SOL: Paper Feed/Print Pressure Out-14	Turns on the paper feed solenoid and the printing pressure solenoid.
15	SOL: Master Feed Clamper Out-15	Turns on the master feed clamper solenoid.
16	SOL: Master Eject Clamper Out-16	Turns on the master eject clamper solenoid.
17	SOL: Master Eject Out-17	Turns on the master eject solenoid.
18	RELAY: Paper Table Down Out-18	Turns on the paper table drive motor (down).
19	RELAY: Paper Table Up Out-19	Turns on the paper table drive motor (up).
20	RELAY: Main Motor Reverse Out-20	Turns the drum in the direction opposite to the printing direction.
21	SIG: Fluorescent Lamp Out-21	Turns on the exposure lamp if the Print key is pressed. Turns off the lamp if the Print key is pressed again.
22	MOTOR: Cutter + Direction Out-22	Turns on the cutter motor (moves it to the rear of the machine).
23	MOTOR: Cutter — Direction Out-23	Turns on the cutter motor (moves it to the front of the machine).
24	MOTOR: Image Shift + Direction Out-24	Turns the image position motor in the "+" direction.

Code	LCD Display	Description
25	MOTOR: Image Shift — Direction Out-25	Turns the image position motor in the "-" direction.
26	MOTOR: Main (10 rpm) Out-26	Turns on the main motor (10 rpm).
27	MOTOR: Main (30 rpm) Out-27	Turns on the main motor (30 rpm).
28	MOTOR: Main (1st Speed) Out-28	Turns on the main motor (1st speed).
29	MOTOR: Main (2nd Speed) Out-29	Turns on the main motor (2nd speed).
30	MOTOR: Main (3rd Speed) Out-30	Turns on the main motor (3rd speed).
31	MOTOR: Main (4th Speed) Out-31	Turns on the main motor (4th speed).
32	MOTOR: Main (5th Speed) Out-32	Turns on the main motor (5th speed).
33	MOTOR: Original Feed Out-33	Turns on the original transport motor.
34	MOTOR: Master Feed Out-34	Turns on the master feed motor.
35	MOTOR: Paper Reverse Out-35	Turns on the paper return motor.
36	Turn on drum, feed/ pressure SOLs Out-36	Turns on the main motor (10 rpm), the paper feed solenoid, and the printing pressure solenoid.
37	MOTOR: Scanner	Turns on the scanner motor. Start by pressing the Print Start key. Stop by pressing the Print Start key again. Then the scanner (carriage) returns to home position when the Print Start key is pressed.
38	SOL: Sheet Insert Out-38	Turns on the master press sheet solenoid.
39	SOL: Sheet Pressure Out-39	Turns on the detection arm release solenoid.
40	MOTOR: Master Buckle Out-40	Turns on the master buffer fan motor.
41	SIG: VHD on Out-41	Applies thermal head voltage.
42	MOTOR: T. Head Up/Down Out-42	Turns on the thermal head pressure release motor.
50	EMF Sorter Mode 1 Out-50	Available only when the EMF Sorter is installed.
51	EMF Sorter Mode 2 Out-51	Available only when the EMF Sorter is installed.
52	EMF Sorter Mode 3 Out-53	Available only when the EMF Sorter is installed.
53	EMF Sorter Mode 4 Out-53	Available only when the EMF Sorter is installed.

Code	LCD Display	Description
60	MODE: Feed Unit U/D (1st Sorter) Out-60	Turns on the paper delivery table motor.
61	MOTOR: Paper Feed (1st Sorter) Out-61	Turns on the 1st transport motor.
62	MOTOR: Paper Feed (2nd Sorter) Out-62	Turns on the 2nd transport motor.
63	MODE: Bin Shift (1st Sorter) Out-63	Turns on the bin shift motor (1st Sorter)
64	MODE: Jogger (1st Sorter) Out-64	Turns on the jogger bar motor. (1st Sorter)
65	MODE: Staple (1st Sorter) Out-65	Turns on the staple motor. (1st Sorter)
66	MODE: Bin Home (1st Sort) Out-66	Moves the bins to the home position. (1st Sorter)
67	MODE: Bin Shift (2nd Sorter) Out-67	Turns on the bin shift motor. (2nd Sorter)
68	MODE: Jogger (2nd Sorter) Out-68	Turns on the jogger bar motor. (2nd Sorter)
69	MODE: Staple (2nd Sorter) Out-69	Turns on the staple motor (2nd Sorter)
70	MODE: Bin Home (2nd Sorter) Out-70	Moves the bins to the home position. (2nd Sorter)
71	MODE: Free Running (Sorter) Out-71	The machine simulates sort speration.
100	MOTOR: Table Down (LCT) Out-100	The LCT tray drive motor moves the tray down.
101	Motor:Table Up (LCT) Out-101	The LCT tray drive motor moves the tray up.
102	MOTOR: Cassette Down Out-102	The LCT cassette bottom plate drive motor moves the plate down.
103	MOTOR: Cassette Up (LCT) Out-103	The LCT cassette bottom plate drive motor moves the plate up.

4.3.6 USER CODE MODE

User Codes

With the user code function, operators must input an authorized code before the machine will operate. The machine keeps track of the number of prints made under each code.

There are 20 user codes as follows:

No.	User Code No.
1	382
2	191
3	182
4	173
5	164
6	155
7	146
8	137
9	128
10	119
11	482
12	291
13	282
14	273
15	264
16	255
17	246
18	237
19	228
20	219

How To Use a User Code

1. Enter the user code (3 digits) with the number keys.
2. Press the Enter key.
3. Press the Master Making key to start printing.

NOTE: The user code mode is reset if the Clear Modes key and the Stop key are pressed together.

SECTION 5
REPLACEMENT AND ADJUSTMENT

5. REPLACEMENT AND ADJUSTMENT

5.1 MASTER FEED

5.1.1 THERMAL HEAD VOLTAGE ADJUSTMENT

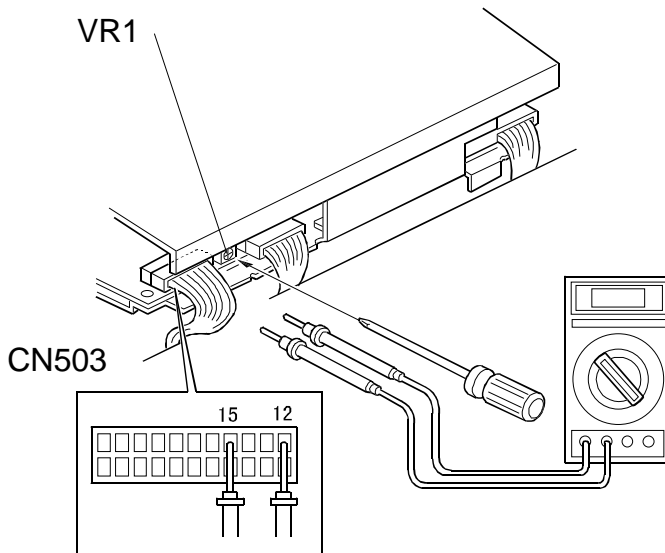

C228R500.WMF

Purpose: To maintain the quality of masters and to extend the life of the thermal head.

Adjustment Standard:

There are two steps.

- 1) The output voltage for the thermal head from the power supply unit must be 22.5 volts (± 0.5).
- 2) The output from the DC/DC converter board is different from one thermal head to another. Refer to the voltage value (X) on the thermal head decal. The output should be between "X-0.1" and "X" volts.

NOTE: This adjustment is always required when the thermal head or power supply unit is replaced.

1. Turn off the main switch and remove the paper exit cover plate (4 screws).
2. Disconnect connector CN503 of the power supply unit.
3. Turn on the main switch, and access the SP mode and select output check mode (SP131) No. 41.
4. Press the Print Start key to apply thermal head voltage continuously (60 seconds).
5. Check the voltage between CN503-15 and CN503-12. If the voltage is not 22.5 volts (± 0.5), turn VR1 on the power supply board to adjust the voltage.

6. Leave the SP mode and turn off the main switch. Then, connect CN503 of the power supply unit.

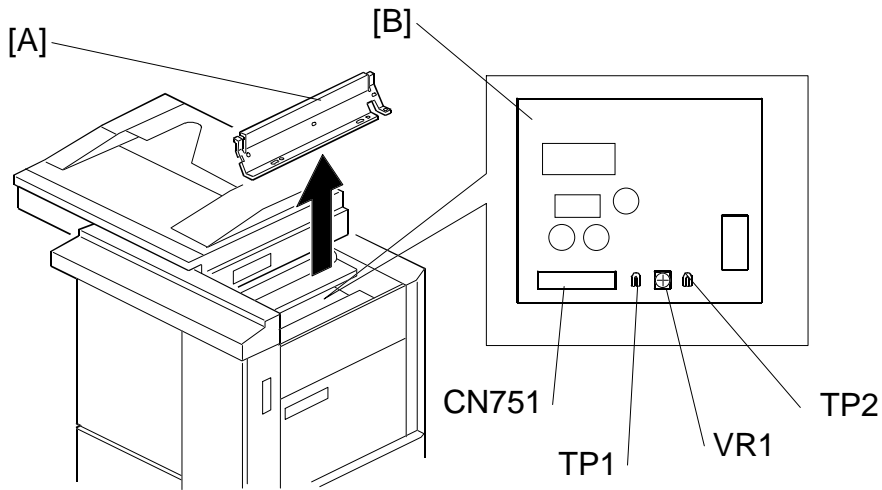

C228R501.WMF

7. Open the scanner unit, and remove the thermal head cover [A].
8. Disconnect connector CN751 on the DC/DC converter board [B].
9. Check the voltage on the thermal head decal. (The value is different from one thermal head to another.)
10. Turn on the main switch.
11. Access the SP mode and select output check mode (SP131) No. 41.
12. Press the Print Start key to apply thermal head voltage continuously (60 seconds).
13. Check the voltage between TP1 and TP2 on the DC/DC converter board. If the voltage is out of the standard range (the value on the thermal head decal ± 0.1 volt), turn VR1 on the DC/DC converter board to adjust the voltage.
14. Leave the SP mode and turn off the main switch. Reinstall the removed parts.

5.2 PAPER FEED

5.2.1 SECOND FEED ROLLER START TIMING

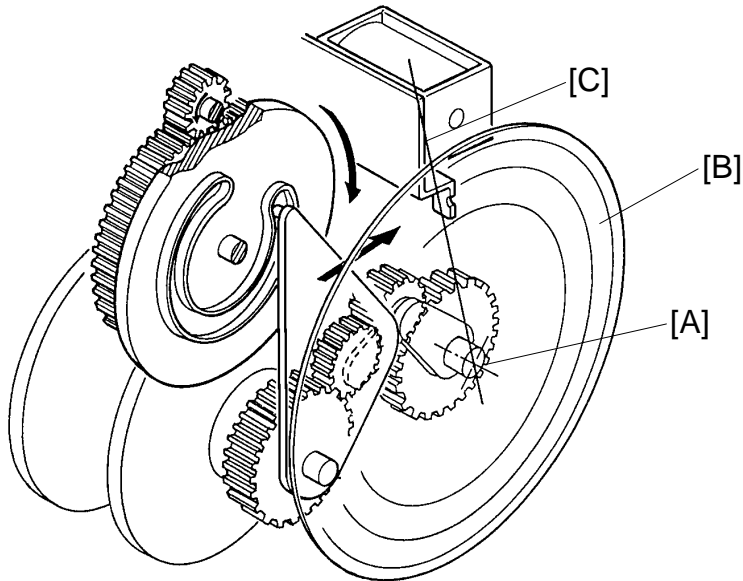

C223R551-1.PCX

Purpose: To ensure correct paper feed by calibrating the second feed roller start timing, and to adjust the leading edge margin.

Adjustment Standard: 144°

1. Set the Image Position indicator to the "0" position and return the drum to the home position by turning the main switch off and on. Then, turn the main switch off and unplug the machine.

2. Remove the rear cover of the machine.

3. Position a protractor [B] on the end of the image shift shaft [A].

NOTE: Align the origin of the protractor with the edge of the solenoid bracket [C].

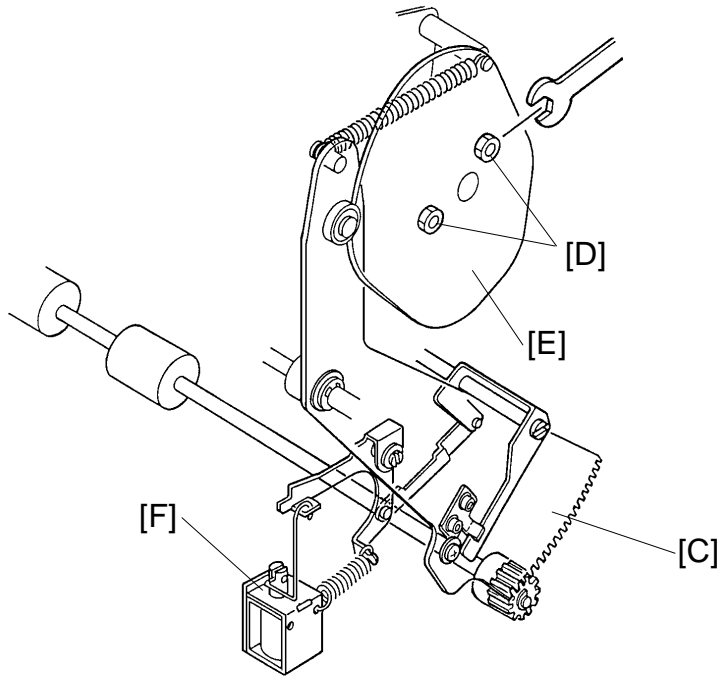

C223R552.PCX

4. Turn on the paper feed solenoid [F] manually and, using a 10 mm spanner, gradually turn the drum rotation shaft.
5. Measure the degrees turned when the second feed roller sector gear [C] starts returning counterclockwise (when the second feed rollers start rotating). This should be 144°.
6. If it is not, loosen the 2 bolts [D] and adjust the second feed roller rotation timing by turning the cam [E].

5.2.2 PAPER FEED ROLLER REMOVAL

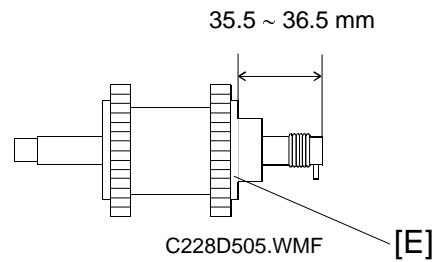
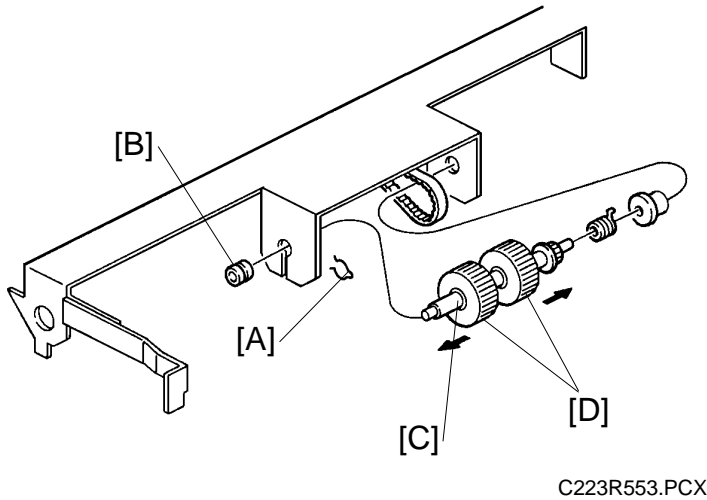

1. Remove the left clip [A].
2. Remove the left bushing [B].
3. Remove the paper feed roller shaft [C].
4. Remove the 2 paper feed rollers [D].

NOTE: When reassembling, make sure that the position of the core roller [E] on the shaft is between 35.5 mm and 36.5 mm from the end of the shaft as shown.

5.3 DELIVERY

5.3.1 EXIT PAWL TIMING ADJUSTMENT

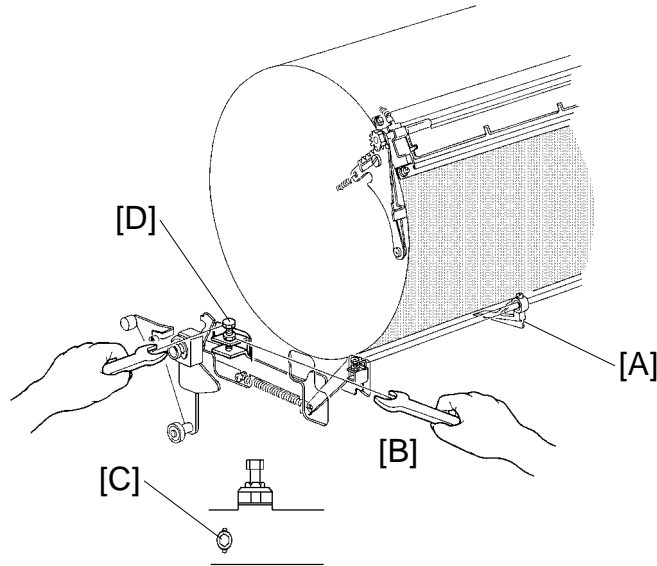

C223R589.PCX

Purpose: To ensure that the exit pawl does not touch the master clamber.

Adjustment Standard: $228 \pm 2^\circ$

1. Remove the rear cover of the machine.
2. Press and hold down the Drum Rotation button until the drum reaches the home position.
3. Position a protractor on the end of the image shift shaft. Position the origin of the protractor at the bracket of the master feed clamber solenoid.
4. Manually press in the plunger of the printing pressure solenoid. Release the paper detection arm manually by rotating the drum rotation shaft with a spanner (10 mm).
5. Measure the degrees turned when the exit pawl [A] comes closest to the drum. This must be $228 \pm 2^\circ$.
6. If it is not, loosen the hexagon nut [B] and screw [C], then adjust the exit pawl position by turning the hexagon bolt [D].
7. Check the adjustment by repeating steps 4 to 6.

SECTION 6
POINT TO POINT DIAGRAM

6. POINT TO POINT DIAGRAM (C228)

Location Map 1/2 (Main Diagram)







- Section A
- Section B
- Section C
- Section D
- Section E
- Section F

Location Map 2/2 (Main Control PCB Details)

- Section G
- Section H
- Section I
- Section J
- Section K
- Section L

NOTE: The symbols and wire color codes used in the diagrams are as follows:

- SYMBOL TABLE -

	AC Line
	DC Line
	Pulse Signal Line
	Signal Direction
	Active High Signal
	Active Low Signal

- WIRE COLOR CODE -

(B) - Black
(C) - Blue
(G) - Green
(H) - Gray
(M) - Purple
(P) - Pink
(R) - Red
(S) - Sky blue
(T) - Brown
(W) - White
(Y) - Yellow
(Z) - Orange

Location Map 1/2 (Main Diagram)

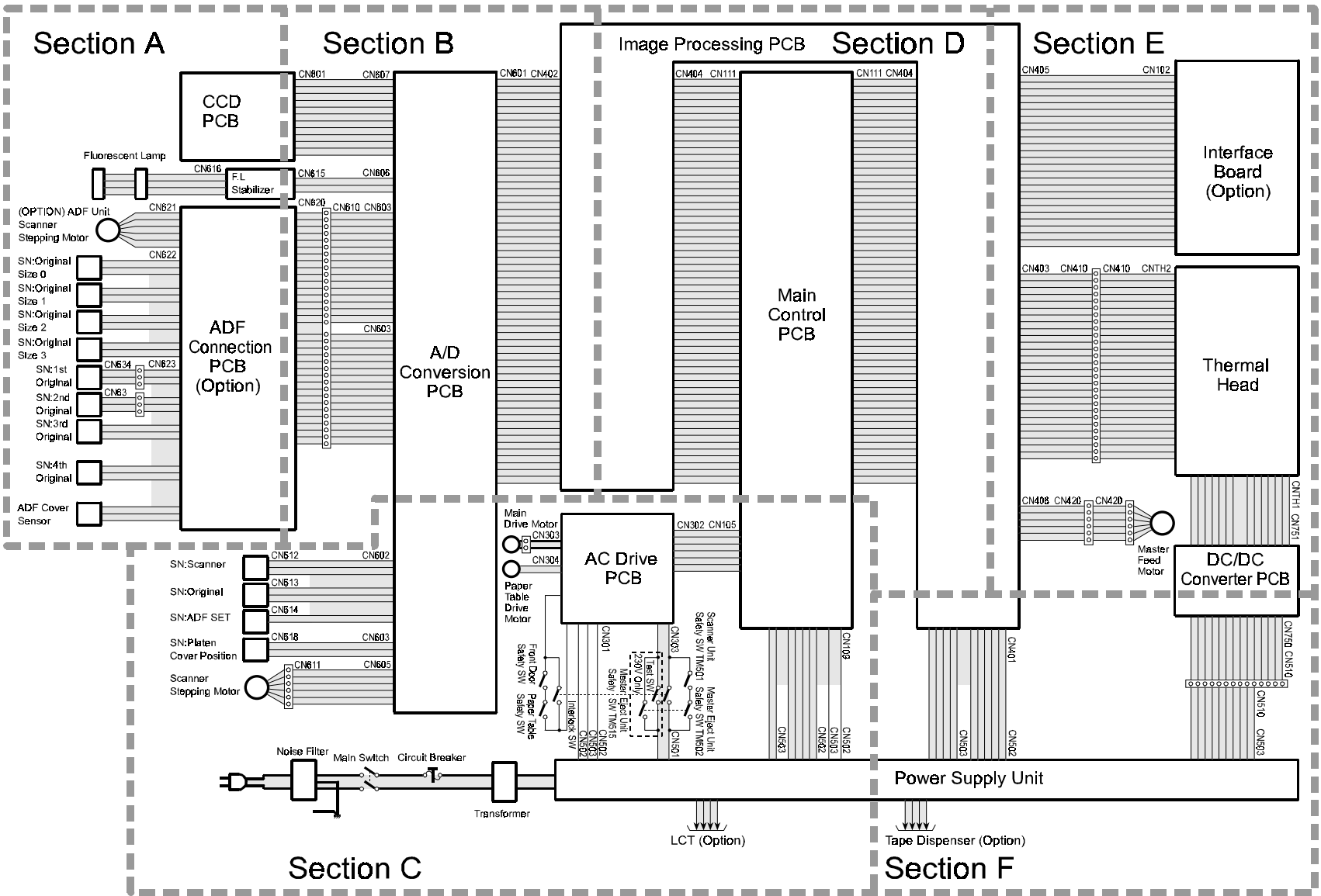

Location Map 2/2 (Main Diagram)

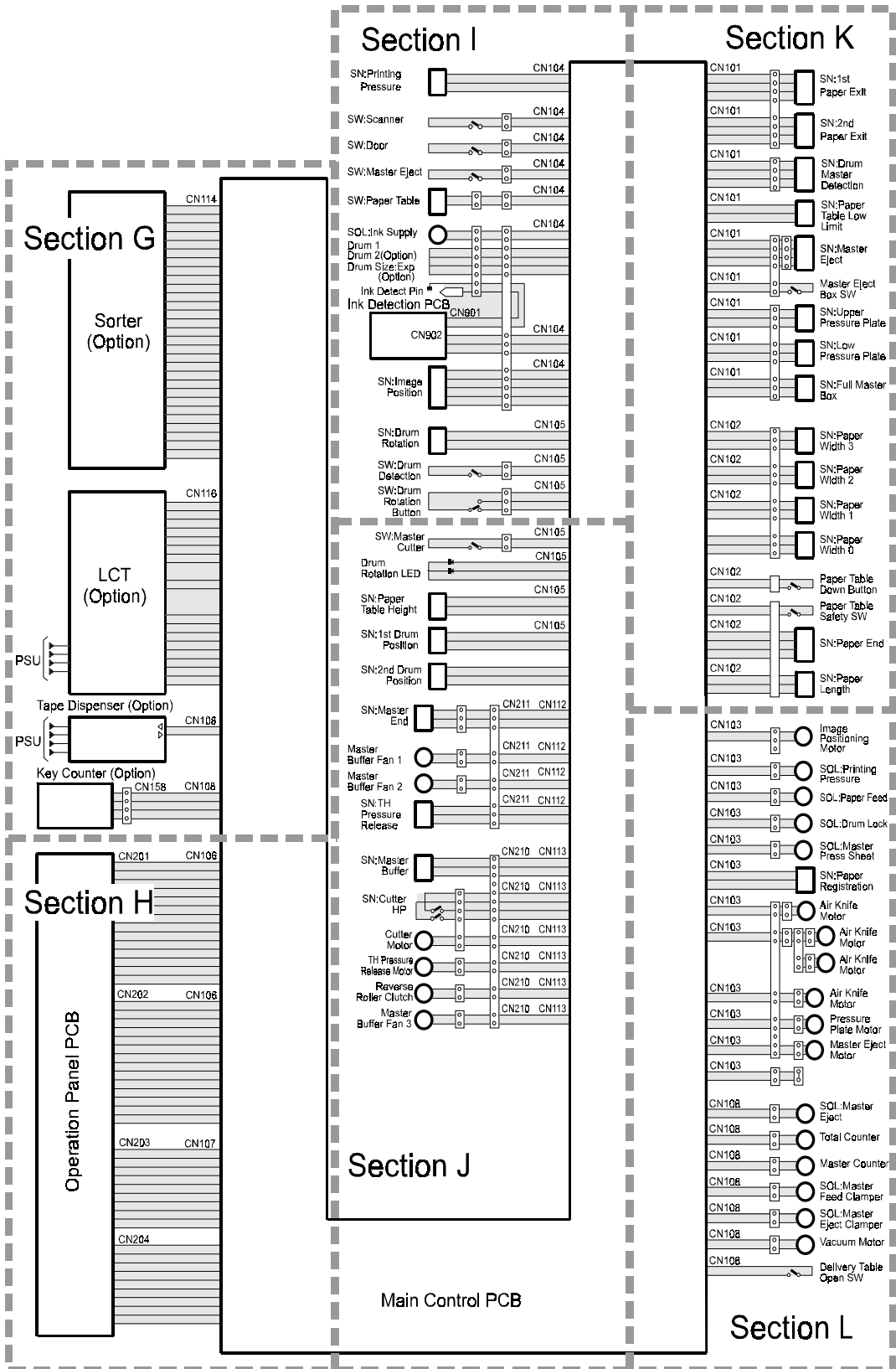

Section A

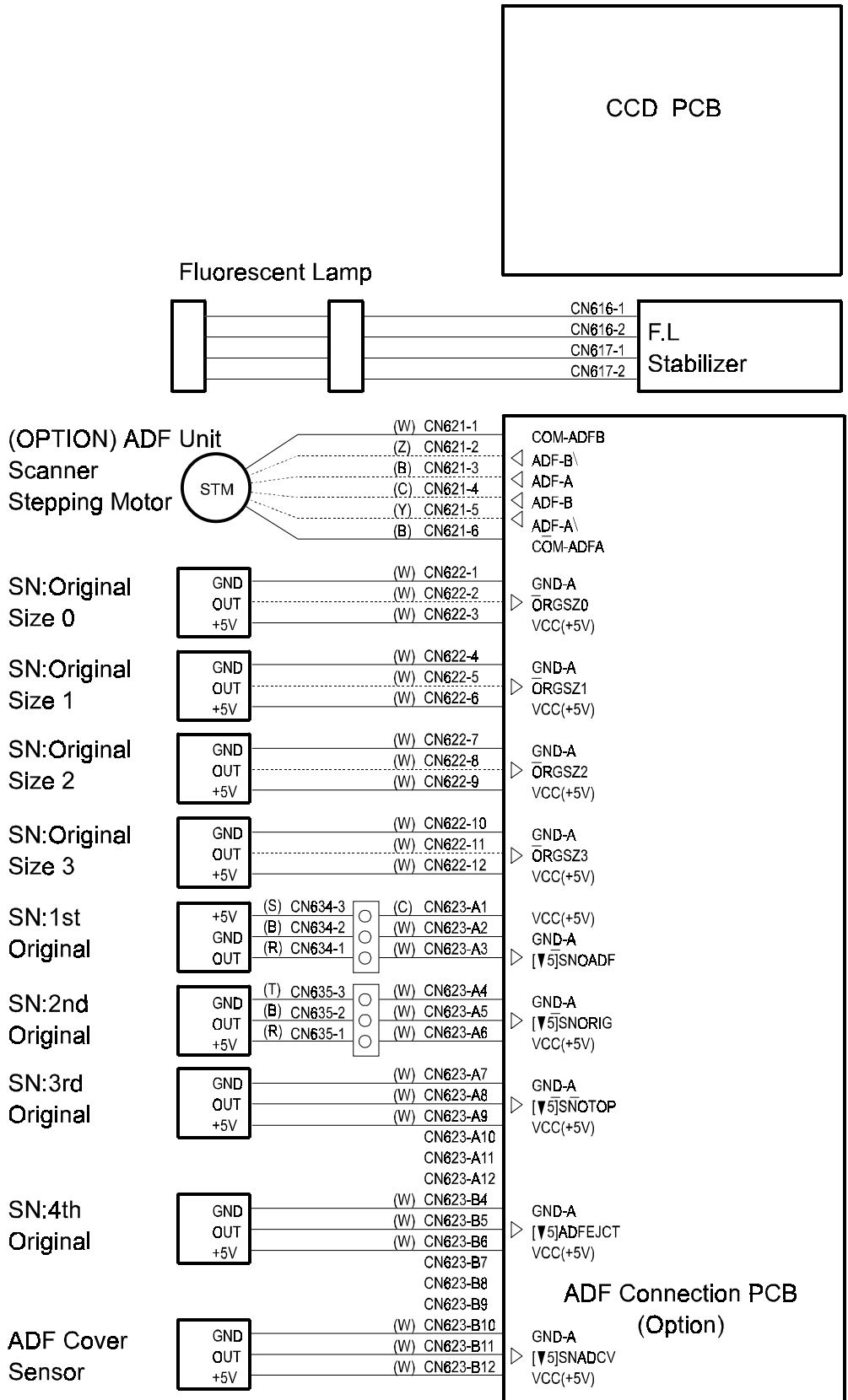

Section B

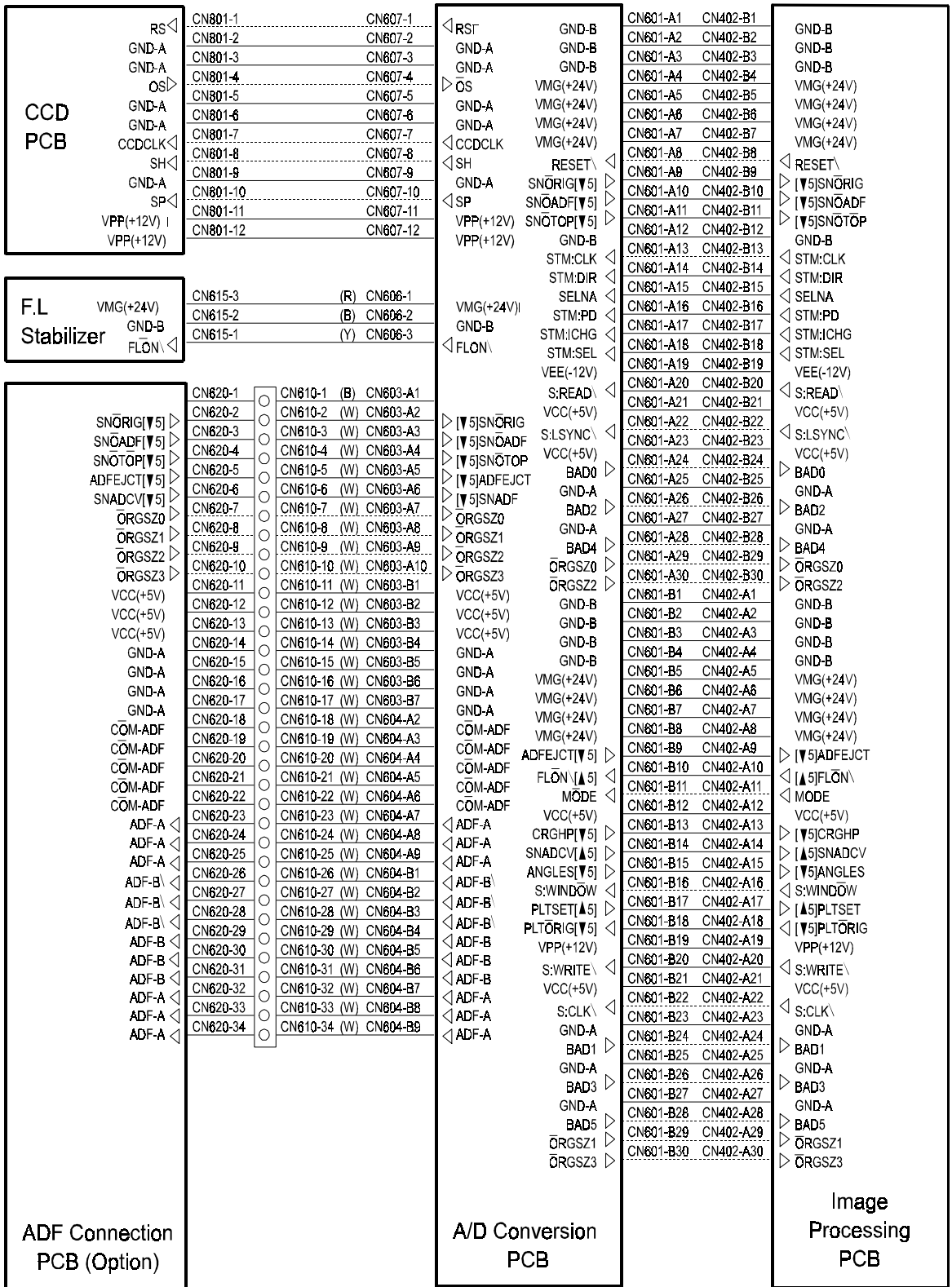

Section C

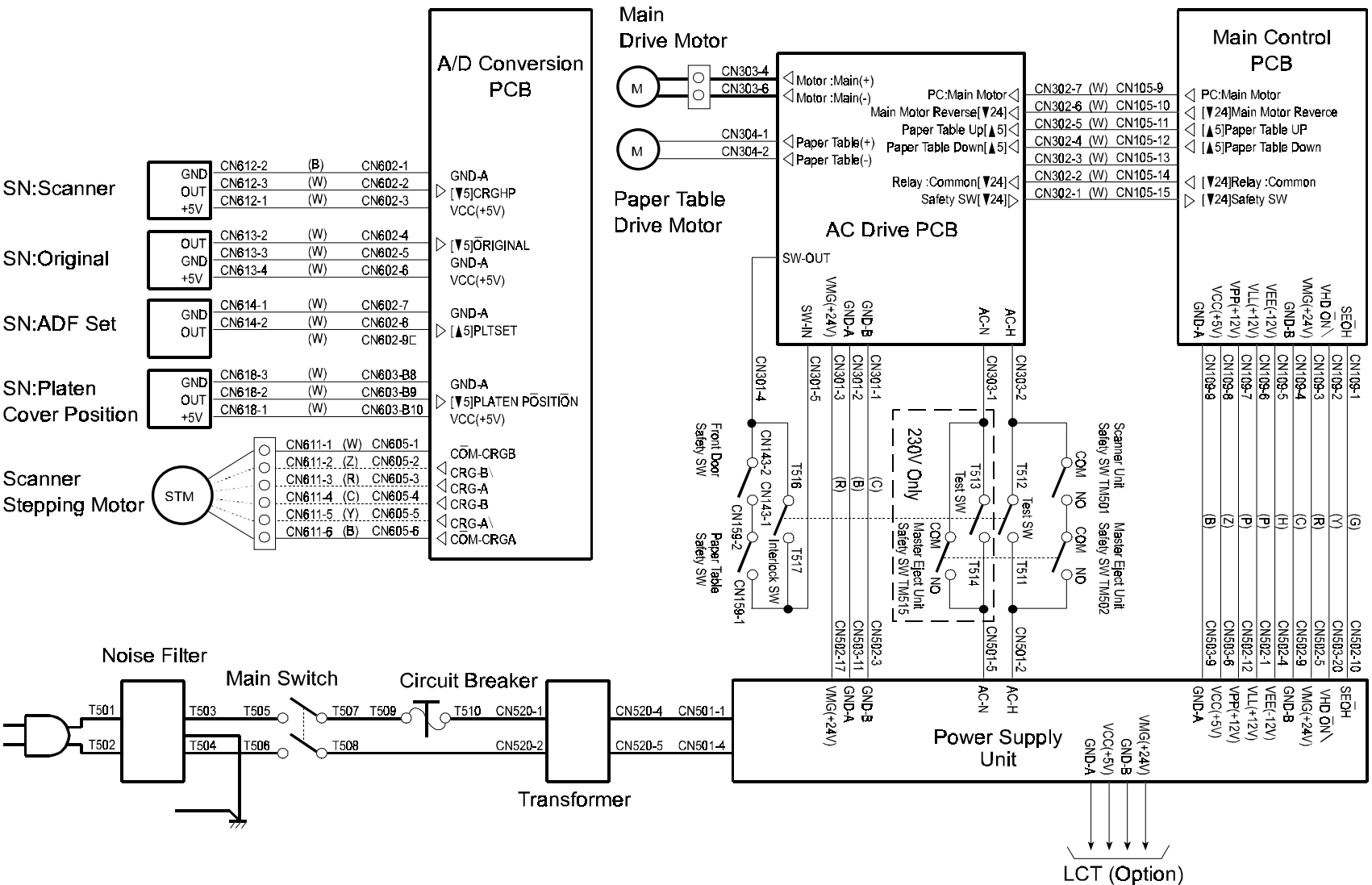

Section D

Image Processing PCB

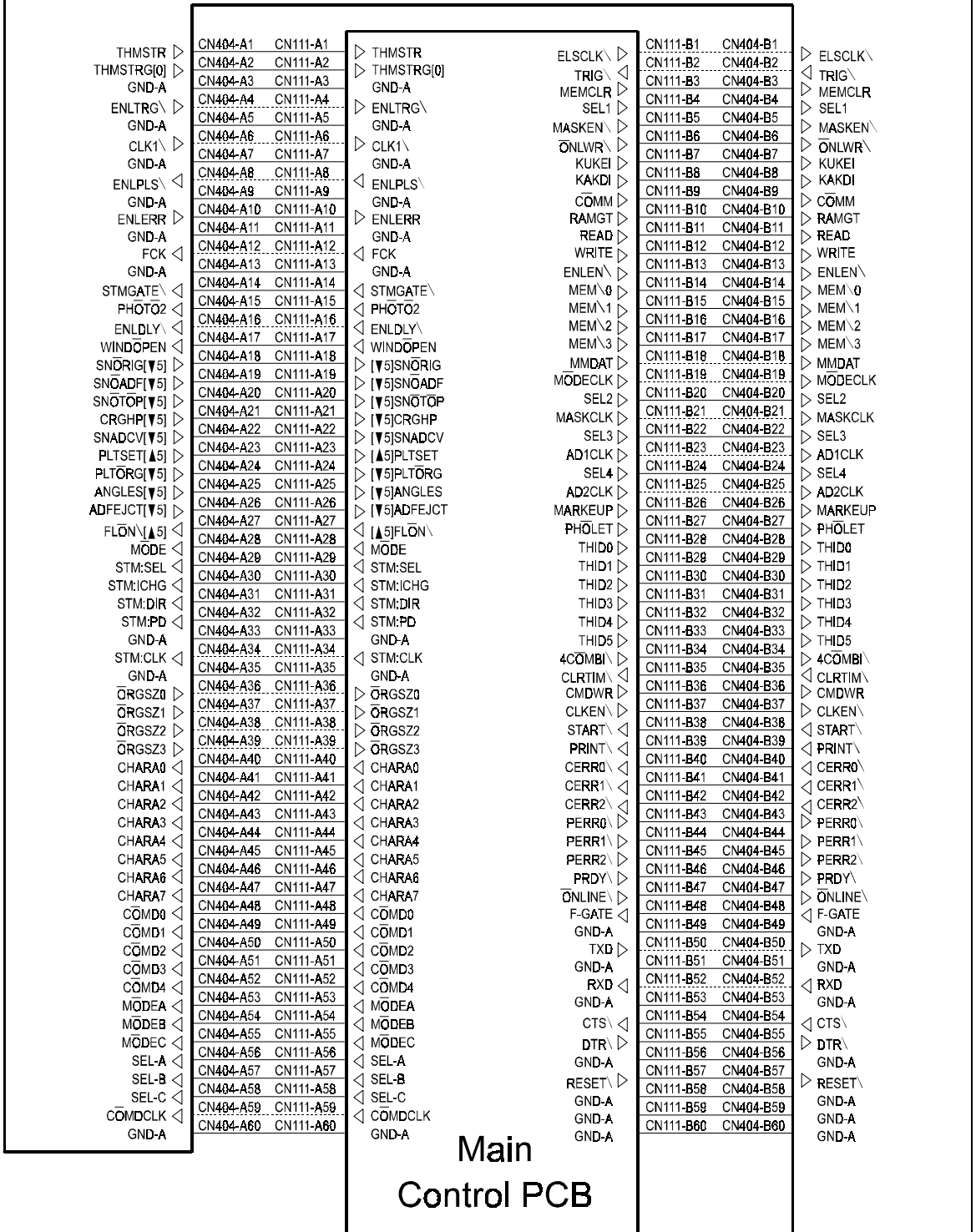

Main
Control PCB

Section E

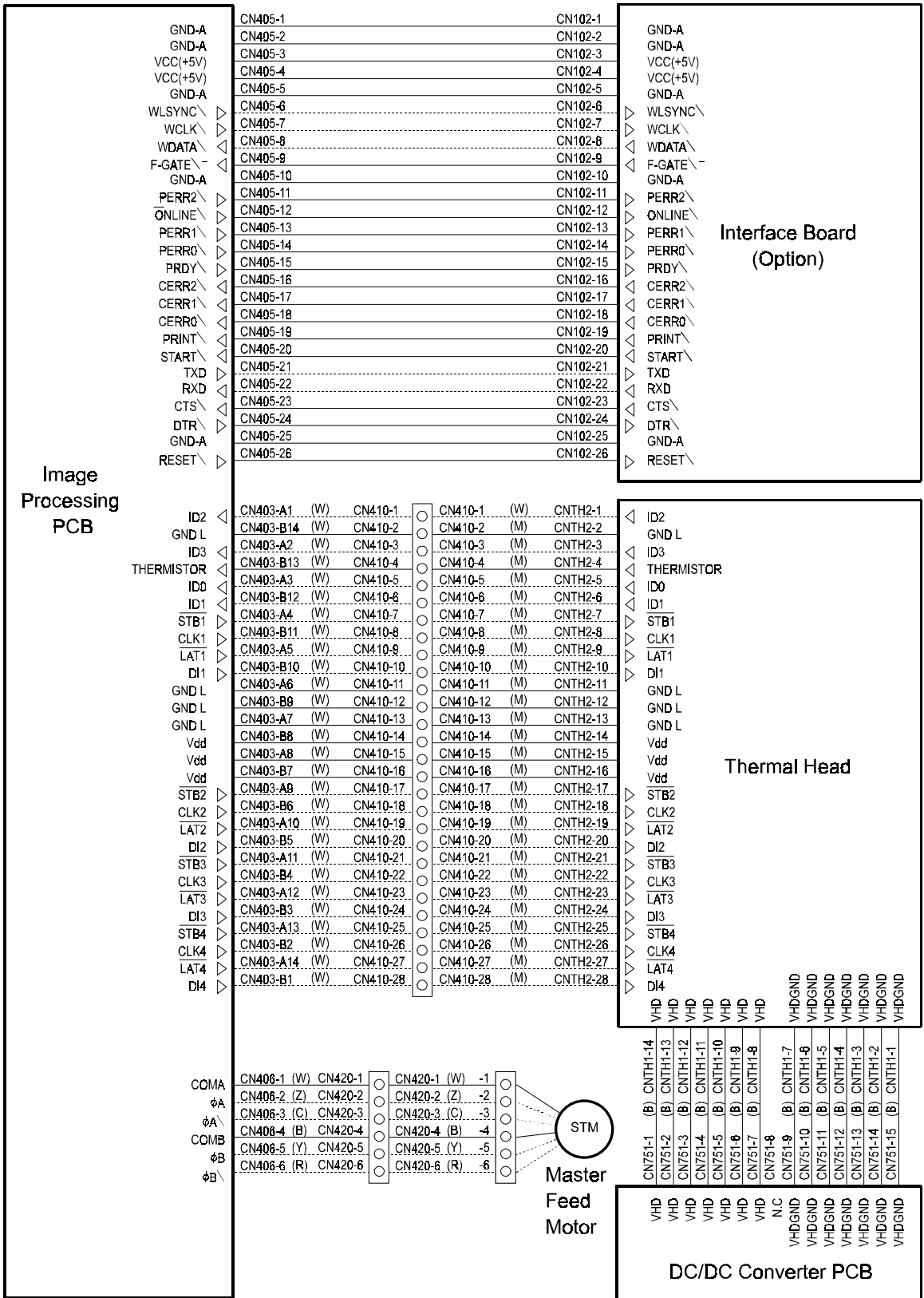

Section F

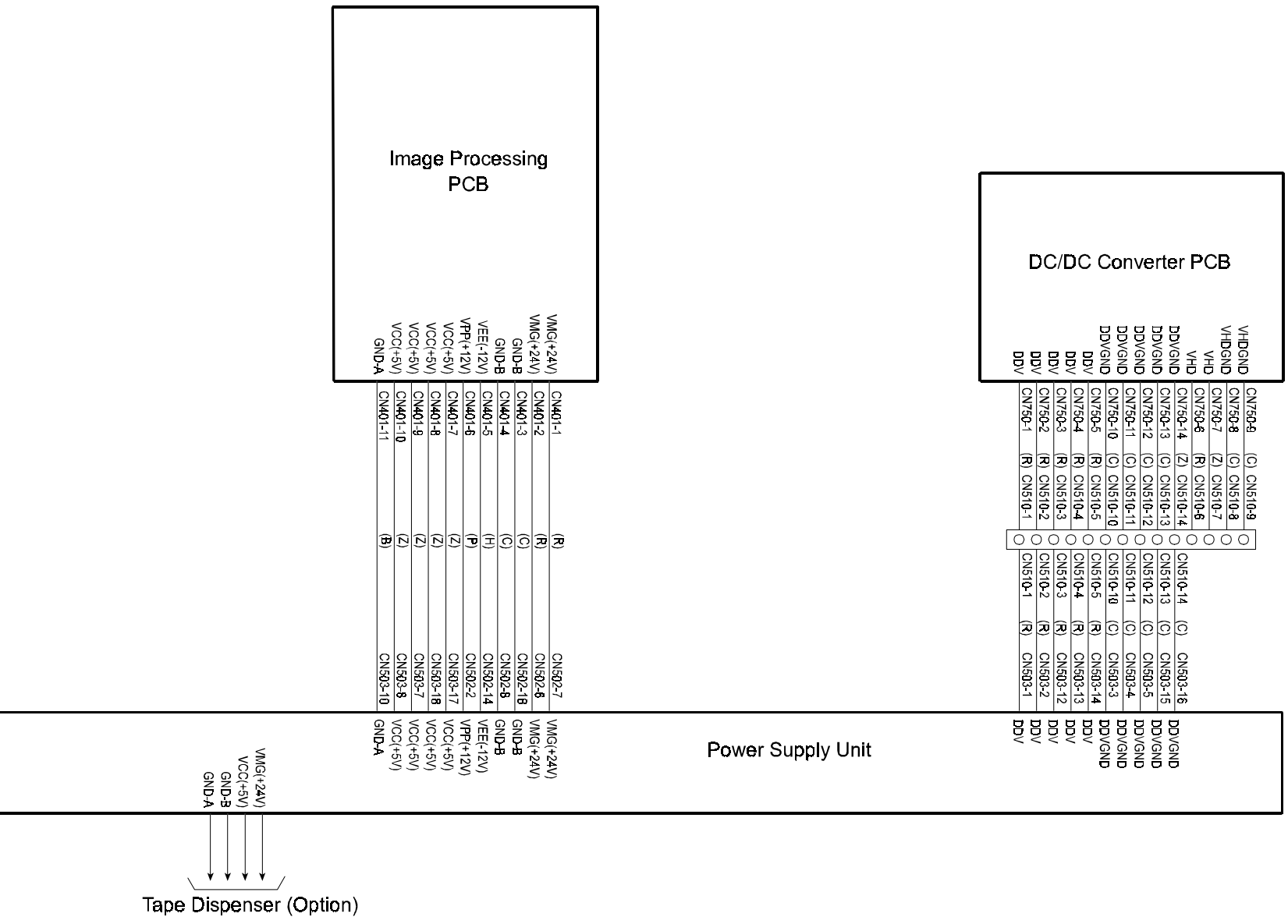

Section G

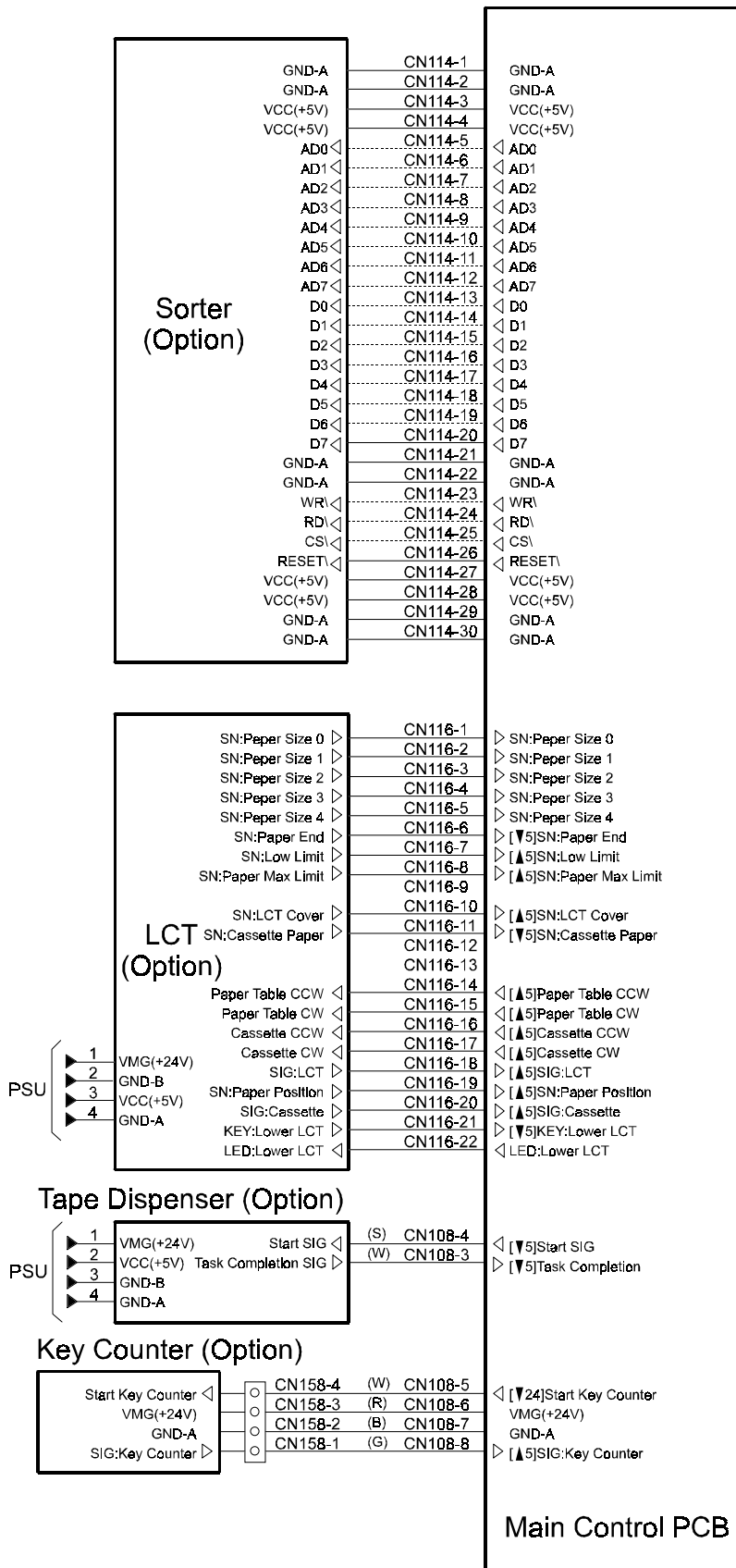

Section H

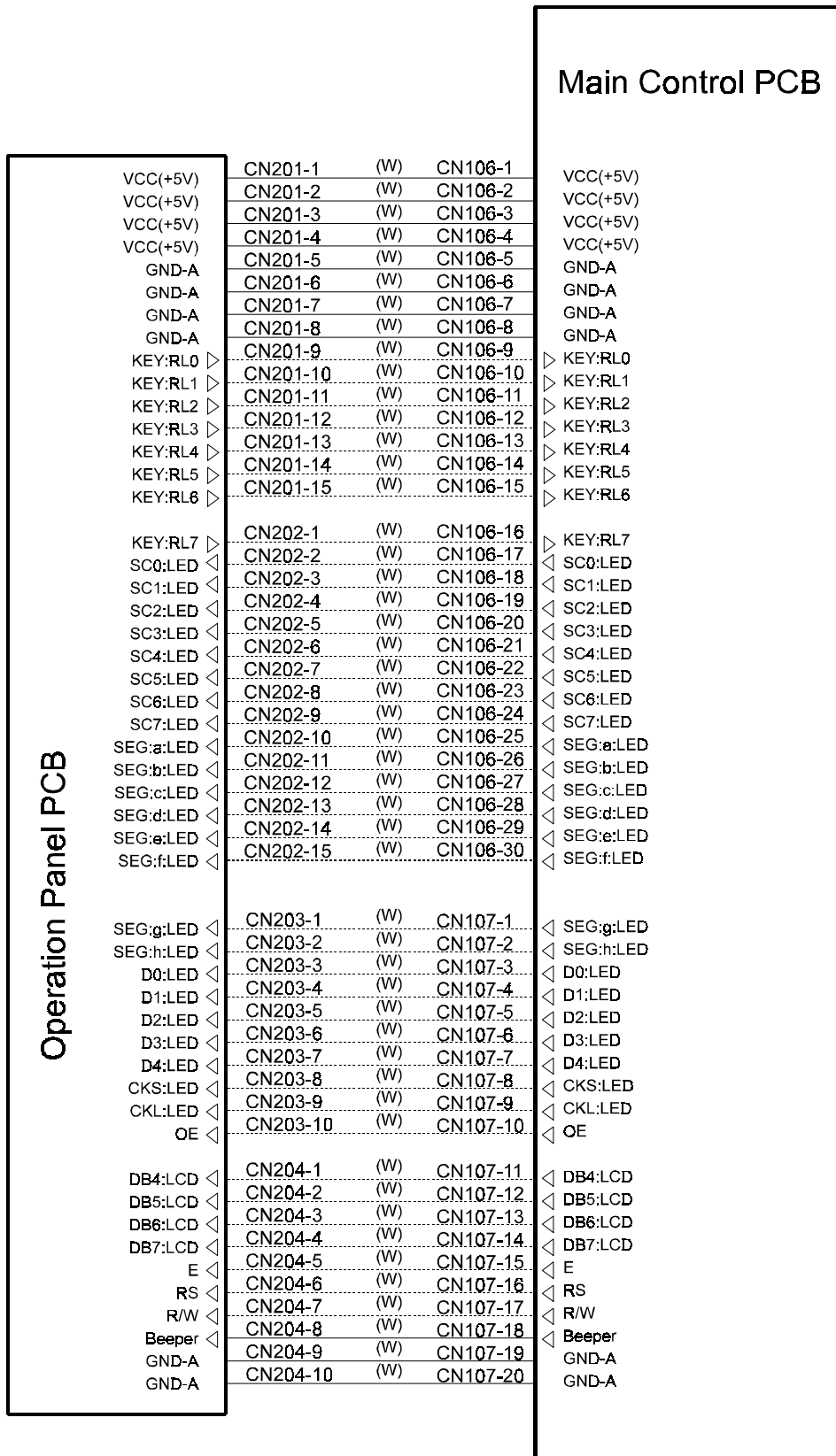

Section I

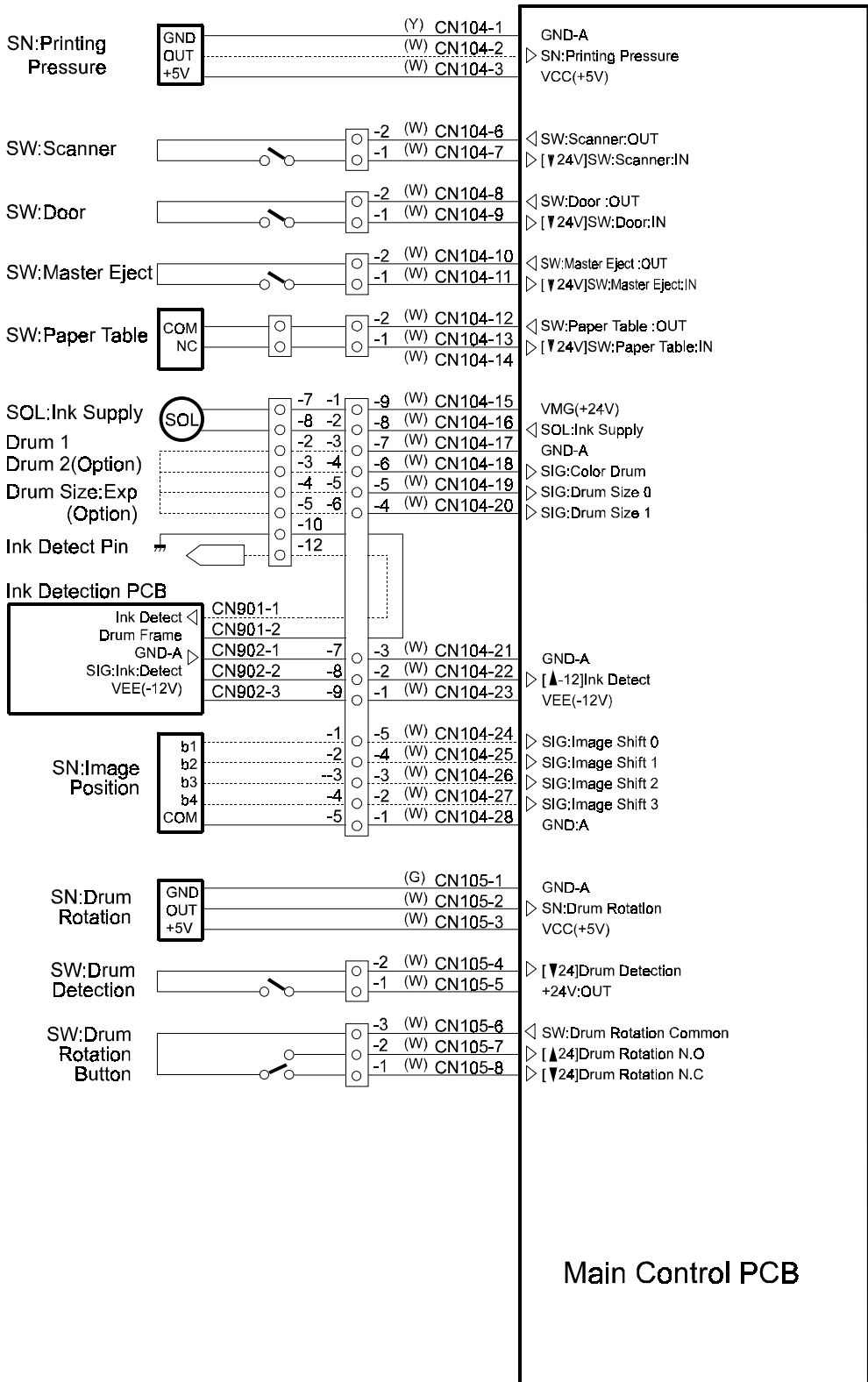

Main Control PCB

Section J

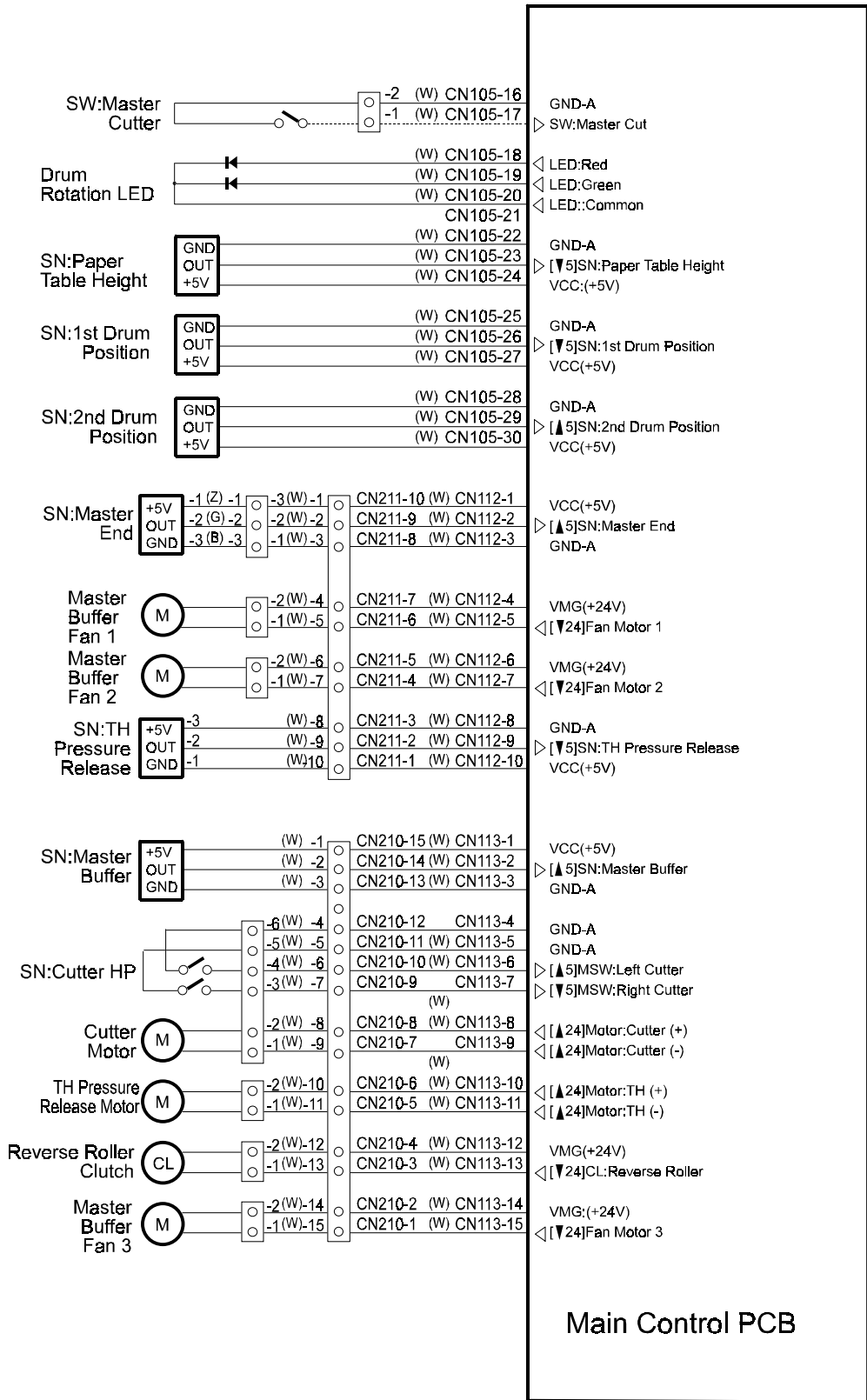

Main Control PCB

Section K

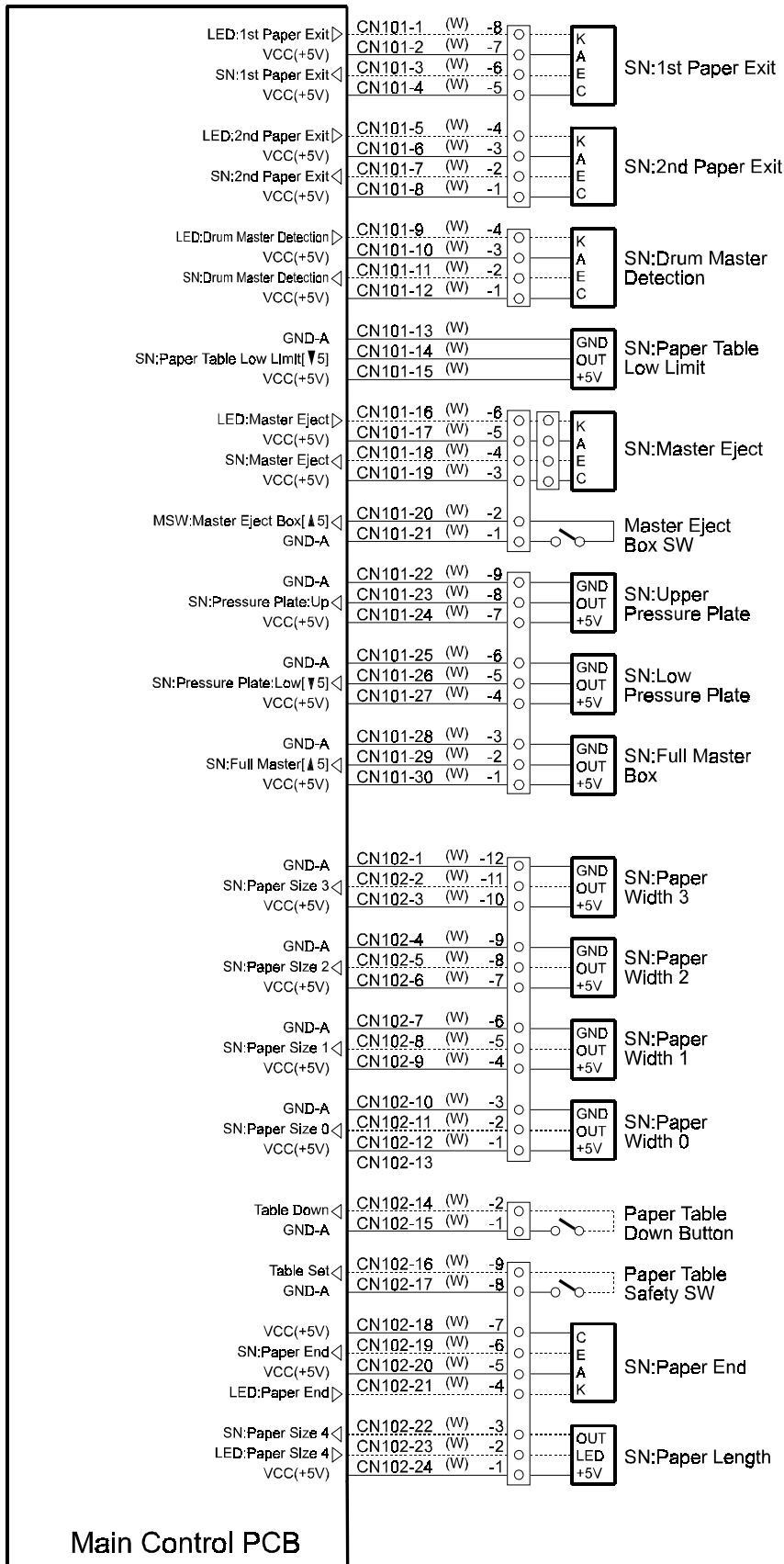

Section L

